

115880 E-CHEMSAVER[®]

MAINTENANCE INSTRUCTIONS

The 115880 e-ChemSaver is a solenoid-actuated shutoff compatible with a wide range of TeeJet nozzle bodies equipped with a diaphragm check valve. It can be used for end-of-boom nozzles as well as individual nozzle shutoff and PWM controls. e-ChemSaver is the commercial given name for an electrical device (a coil that creates pulses) connected on each nozzle body.

The valve is normally closed and opens when the solenoid is energized. The 115880 has a 2-Pin SuperSeal 1.5 connector molded into the body for a clean, weather-tight electrical connection. This technical component works under a very high frequency; 20Hz (meaning 20 open/close cycles per second). Within this frequency level, is crucial to maintain the e-ChemSaver properly.

e-ChemSavers Precautions

A few general maintenance steps will assist in maintaining a properly working system. See your sprayer manufacturer's recommended maintenance and inspection procedures for additional information.

Water's Quality

Is very important to use solid particle's free water (such as sand, metal chips, calcium...). Pay special attention when filling from a natural source, or a different one from a domestic. To filter while filling the tank is highly recommended in spite of the origin, with at least a 80mesh strainer.

Plant Protection Products

Any product silicon-based is FORMALLY MISADVISED, as it is harmful for the e-ChemSavers. In a general way, pay attention to any PPP containing solid particles.

Filtration

Any special survey to the filtration conditions is highly recommended during the applications Use at least 80mesh strainers.

Cables

Prior to operating, check all connections, including all solenoid connections, for corrosion, water, damaged pins, etc. See the External Inspection section for examples of proper gasket sealing.

Prevent potential moisture contamination issues by using anti-corrosion products or small form of silicone at each connection, especially the solenoid connections.

Strainers

Remove and clean all the product strainers. Replace the strainers after they are clean and dry.

System Flush

1. Fill the product tank with at least 200 gallons / 750 liters of clean water.
2. If the boom tubes have a flush valve at the end, open the flush valves and flush the boom tubes with 100 gallons / 375 liters of clean water.
3. Remove or open the spray nozzles and flush the booms with the remaining water.

While in use

Rinse system with clean water after each application. 80 mesh strainer screen or finer is recommended with all e-ChemSaver applications. The product screen on the discharge side of the pump should match manufacturer recommendation.

When Using Fertilizer or Chalky Substances

Fertilizer has a tendency to plug screens faster than water if left out to settle.

- Ensure the machine is cleaned out daily and does not sit with product in the application system overnight.
- Verify that without solenoids operating the system does not exhibit any flow issues.
- Ensure 80 mesh screens are clean and free of debris.

Storage

When not actively using the system, a few general maintenance steps will assist in maintaining a properly working system for the next season. See your sprayer manufacturer's recommended storage procedures for additional information.

1. Empty product from the chemical supply tank.
2. Flush the application system with water.
3. Flush the application system with tank cleaner.
 - Purchase a tank cleaner. Follow the manufacturer's directions for water quantity and dilution rate.
 - Rinse the tank according the tank cleaner directions. Do not let the tank cleaner sit in the spray boom or e-ChemSavers. Tank cleaner must be completely flushed out of the system.
4. After rinsing with the tank cleaner, flush the spray boom and nozzles with 50 - 100 gallons / 200 - 375 liters of clean water.
 - If applying a water-based product, flush the system with soap and water.
5. If Winterizing – Prime the system plumbing with a water and automotive antifreeze mixture appropriate for the local environment to prevent freezing of valve components.





E-CHEMSAVER MAINTENANCE

With proper equipment maintenance (as recommended by the equipment or chemical manufacturer), TeeJet solenoids are designed to provide up to 500 hours maintenance free operation. The following solenoid maintenance procedures should be performed on the solenoid or on individual nozzles if leaks are observed at a specific spray nozzle.

Regular inspection of the e-ChemSaver is required for optimal functionality and proper operation under any circumstances.

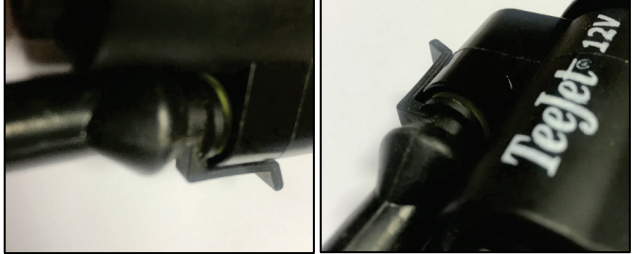
External Inspection

The following parts should be visually inspected before each use.

Inspection Area	Procedure	Example
<p>Gasket Seal</p>	<p>The correct gasket seal ensures a proper connection of the cable.</p> <p>In case of difficulty when connecting the cable, apply special grease to ensure a proper connection.</p>	<p>Gasket OK</p>  <p>Gasket Not OK</p> 
<p>Tighten Tension between the e-ChemSaver and the nozzle body</p>	<p>Install by hand, tightening until a complete block.</p>	
<p>Rear Nut's Tighten Tension</p>	<p>Install by hand, tightening until a complete block. Afterwards ensure it with an additional 1/4 of turn with an appropriate tool.</p>	

Internal Inspection

After any inspection, reassemble all the parts as shown in the Solenoid Disassembly and Reassembly instructions referred in this bulletin.

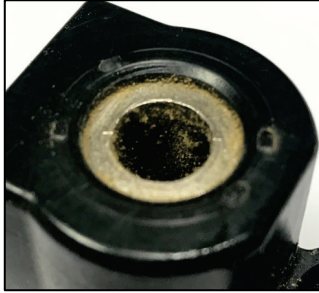
Inspection Area	Procedure	Example
Coil Assembly (2)	If any external body was present in the stainless-steel tube, clean using dry, forced air.	<div style="display: flex; justify-content: space-around;"> <div style="text-align: center;"> <p>Clean and Proper</p>  </div> <div style="text-align: center;"> <p>Dirty</p>  </div> </div>
O-Ring (9)	Observe that the O-ring is well well-maintained. In case of degradation, replace it.	<p>Proper O-Ring</p> 
O-Ring (8)	Observe that the O-ring is well well-maintained. In case of degradation, replace it.	
Interface Cap (7)	Clean using clear water. Do not use any tool. In case of need, a paintbrush can be use as well as pressurized air.	<p>Blocked or Plugged Holes</p> 
Tube Sub-Assembly (3) Internal	If any solid is present, clean with water.	<div style="display: flex; justify-content: space-around;"> <div style="text-align: center;"> <p>Dirty</p>  </div> <div style="text-align: center;"> <p>Clean</p>  </div> </div>

Inspection Area	Procedure	Example
<p>Tube Sub-Assembly (3)</p>	<p>Clean and inspect the Tube Sub-Assembly (4). Replace the tube assembly if the rubber seal is worn or damaged.</p>	<p>Before</p>  <p>After</p> 
<p>Brown O-Ring (6)</p>	<p>Observe that the O-ring is well well-maintained. In case of degradation, replace it.</p>	<p>Proper O-Ring</p> 
<p>Stainless Steel Spring (5)</p>	<p>Inspect. Replace if necessary.</p>	
<p>Plunger (4) gasket</p>	<p>If a severe degradation, replace the complete kit (Reference AB115880-2-KIT).</p>	<p>Gasket OK Gasket Not OK</p> 

SOLENOID DISASSEMBLY AND REASSEMBLY

NOTE: O-rings (6, 8, 9) should be handled with care as they can be damaged/deformed.

Disassembly

1. Loosen and remove the nylon Nut (1).
2. Separate the Coil Assembly (2) from the rest of the Tube/Plunger Assembly (3-10).
3. Remove the Locking Ring (10).
4. Using e-ChemSaver (CP116231-NYB) wrench or pliers to grip the stainless steel Interface Cap (7), loosen the Tube Sub-Assembly (3) using a 14 mm / 9/16" or adjustable wrench.

All repairable parts should be accessible at this point. The Plunger Sub-Assembly (4), stainless steel Spring (5), and O-rings (6, 8, 9) can be replaced without further disassembly.

Reassembly

5. During reassembly, place the Plunger Sub-Assembly (4) and stainless steel Spring (5) in the Tube Sub-Assembly (3).

NOTE: The Plunger Sub-Assembly (4) should be orientated with the black insert facing outward (visible) when placed in the Tube Sub-Assembly (3).

6. While compressing the Spring (5), thread the Tube/Plunger Assembly (3-10) to the stainless steel Interface Cap (7) and tighten using a wrench and pliers.
 - ▶ Optional: Apply 1 drop of Loctite Blue 243 to the threads of the Interface Cap (7) and Tube Sub-Assembly (3).
 - ▶ Torque Specifications: Tighten Interface Cap (7) and Tube Sub-Assembly (3) to 1.36 N-m / 12 in-lbs.
7. Return the Locking Ring (10) to its original position and slide the Tube/Plunger Assembly (3-10) through the Coil Assembly (2).

NOTE: The Coil Assembly (2) should be orientated with the SuperSeal 1.5 connector facing away from the Interface Cap (7).

8. Tighten the nylon Nut (1) to the Tube/Plunger Assembly (3-10).

Verification After Reassembly

9. Lubricate O-ring (9) before re-attaching the e-ChemSaver to the nozzle body.
10. Attach the solenoid on the nozzle body and inspect for leaks when system is on.

RECOMMENDED: At the time of installation, prior to plugging in the connector, spray a sufficient quantity of CorrosionX®, CorrosionX® Heavy Duty, or CorrosionX® Aviation corrosion prevention compound into the connector to wet the terminals.

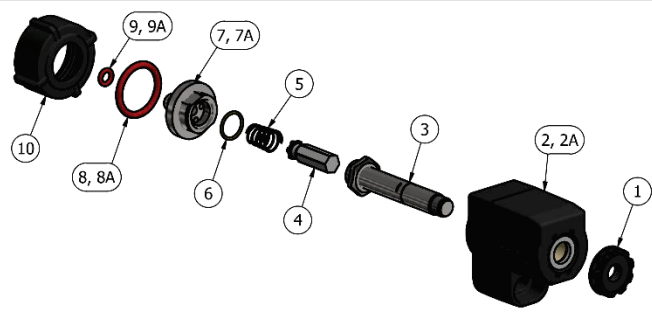

ITEM	PART NUMBER	DESCRIPTION
1	CP55289-NYB	NUT, NYLON-BLACK
2	CP115881-12	12V COIL ASSEMBLY
2A	CP115881-24	24V COIL ASSEMBLY
3	N/A	TUBE SUB-ASSEMBLY
4	N/A	PLUNGER SUB-ASSEMBLY
5	N/A	SPRING, 302 STAINLESS STEEL
6	N/A	O-RING, VITON®
7	N/A	INTERFACE CAP, 303 STAINLESS (115880-1-12 & 115880-4-12)
7A	N/A	INTERFACE CAP, 303 STAINLESS (115880-2-12)
8	CP7717-2/116-VI	O-RING, VITON® (115880-1-12 & 115880-2-12)
8A	CP58589-VI	GASKET, VITON® (115880-4-12)
9	CP7717-2-007/VI	O-RING, VITON® (115880-1-12 & 115880-4-12)
9A	CP7717-M4.2X1.9-VI	O-RING, VITON® (115880-2-12)
10	CP55288-NYB	LOCKING RING, NYLON-BLACK

SPARE KITS	
AB115880-1-KIT, SPARE PARTS KIT (INCLUDES ITEMS 4, 5, 6, 8, 9)	
AB115880-2-KIT, SPARE PARTS KIT (INCLUDES ITEMS 4, 5, 6, 8, 9A)	
AB115880-4-KIT, SPARE PARTS KIT (INCLUDES ITEMS 4, 5, 6, 8A, 9)	
AB115880-1-FR-KIT, FIELD REPAIR KIT (INCLUDES ITEMS 1, 3, 4, 5, 6, 7, 8, 9)	
AB115880-2-FR-KIT, FIELD REPAIR KIT (INCLUDES ITEMS 1, 3, 4, 5, 6, 7A, 8, 9A)	

VITON® IS A REGISTERED TRADEMARK OF THE CHEMOURS COMPANY.

DESCRIPTION: 115880-1-12, 115880-2-12, 115880-4-12, 115880-1-24, 115880-2-24, 115880-4-24 e-CHEMESAVER® SOLENOID OPERATED ELECTRIC SHUT-OFF VALVE			
REVISION NO.	2		
REFERENCE	02/20/2020	SHEET	1 OF 1 DWG SIZE: A

e-ChemSaver Models

If, for any reason, the change of the complete e-ChemSaver is mandatory, there exist 3 different models. For choosing the right one, refer to the interface cap (7) indicating the number of different points marked on it.

- **1 MARK** – Reference 115880-1-12.
- **2 MARKS** – Reference 115880-2-12. (above image)
- **4 MARKS** – Reference 115880-4-12.

Figure 1: Model Markings



TROUBLESHOOTING

This is a list with the most common e-ChemSaver's failures.





NOZZLE LEAKING

After setting off the spray, some nozzles are still leaking.

Issue/Problem	Solution	Example
Plunger's gasket damaged	Change the kit plunger-gasket (Reference AB115880-2-KIT).	
Solid particles present in the gasket	Remove any solid particle present. Clean smoothly with pressurized air.	<p data-bbox="799 747 1078 772">Sand Dust Blocking the Closure</p>  <p data-bbox="799 1104 1102 1129">Metal Chip Inserted In The Gasket</p> 
Stuck plunger in the cylinder due to solid/liquid particles	Clean with water.	<div style="display: flex; justify-content: space-around;"> <div data-bbox="799 1455 1002 1793"> <p data-bbox="799 1461 943 1486">Stucked Plunger</p>  </div> <div data-bbox="1086 1455 1278 1793"> <p data-bbox="1086 1461 1198 1486">Free Plunger</p>  </div> </div>

The e-ChemSaver Doesn't Open

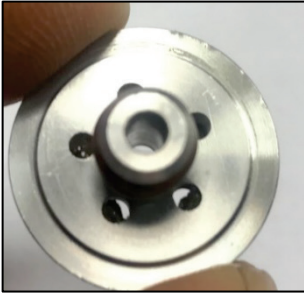
During the spray, some nozzles remain closed not working. Probable causes and solutions.

Issue/Problem	Solution	Example
Blocked, dirty or stuck nozzle	<i>Clean the nozzle with water.</i>	
Damaged electrical connector	<i>Change the coil (Reference CP115881-12).</i>	
Broken or defective coil, pulse is not heard or detected	<i>Change the coil (Reference CP115881-12).</i>	
Stuck e-ChemSaver	<i>Disassemble the e-ChemSaver and clean all the holes with clean water.</i>	
Spray pressure over max working pressure	<i>Lower the working pressure, the e-ChemSaver doesn't admit pressures higher than <u>7 bar / 100 psi</u>.</i>	

Incorrect e-ChemSaver Flow

While controlling the flow nozzle by nozzle, one of them or a section is not spraying the exact amount of volume per time. Probable causes and solutions.

Ensure that the flow is adequate to the nozzle within the legislation setting the system to a 100% duty cycle.

- Set the system up to a 100% duty cycle

If the problem persists (taking account a +/-5%cv) the e-ChemSaver can cause the problem by itself

- The cylinder holes are blocked. Proceed as explained previously.
- The plunger's gasket is broken or damaged. Replace the kit as explained previously.
- Electrical current is not enough. Usually system's voltage should be between 11 and 14V. Out of this Interval, an alarm will be shown in the screen.

Other Relevant Information

Issue/Problem	Solution	Example
Can I clean it with high pressure water?	It is possible. Try not to aim insisting on the e-ChemSavers for too long time, particularly to the electrical connector.	