

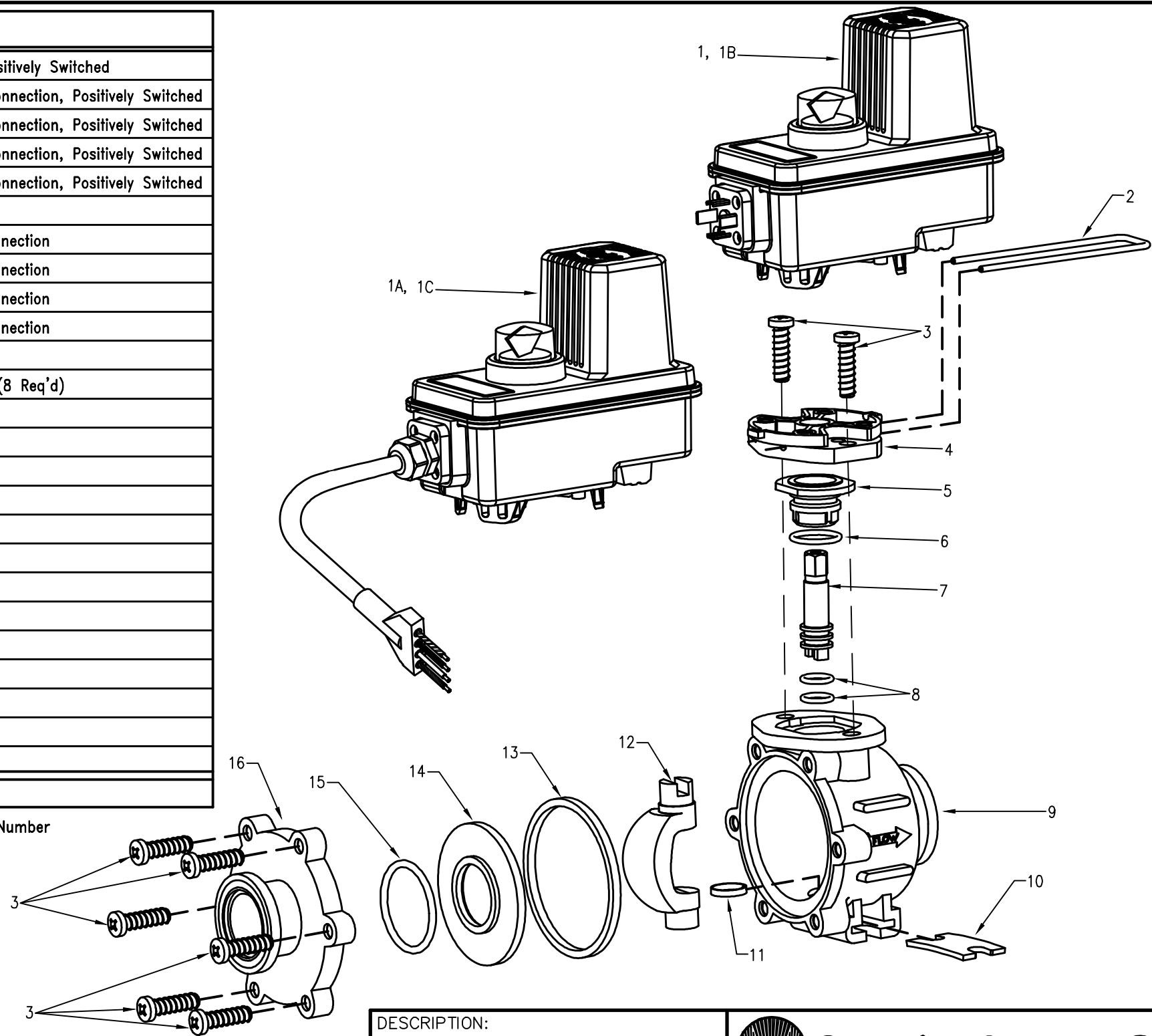

ITEM	PART NO.	DESCRIPTION	
1	50515-25DP ■	BEC Motor, 25-RPM (0.6-SEC), DIN Connection, Positively Switched	
1A	50515-25CP03 ■	BEC Motor, 25-RPM (0.6-SEC), 0.3-Meter Cable Connection, Positively Switched	
	50515-25CP05 ■	BEC Motor, 25-RPM (0.6-SEC), 0.5-Meter Cable Connection, Positively Switched	
	50515-25CP15 ■	BEC Motor, 25-RPM (0.6-SEC), 1.5-Meter Cable Connection, Positively Switched	
	50515-25CP60 ■	BEC Motor, 25-RPM (0.6-SEC), 6.0-Meter Cable Connection, Positively Switched	
1B	50533-25D	BE Motor, 25-RPM (0.6-SEC), DIN Connection	
1C	50533-25C03	BE Motor, 25-RPM (0.6-SEC), 0.3-Meter Cable Connection	
	50533-25C05	BE Motor, 25-RPM (0.6-SEC), 0.5-Meter Cable Connection	
	50533-25C15	BE Motor, 25-RPM (0.6-SEC), 1.5-Meter Cable Connection	
	50533-25C60	BE Motor, 25-RPM (0.6-SEC), 6.0-Meter Cable Connection	
2	CP50517-SSPV	Retaining Clip, 304 Stainless Steel - Passivated	
3	CP45517-1 1/8-SS	Screw, Phillips/Sq. Pan Head, 302 Stainless Steel (8 Req'd)	
4	CP50514-PP	Motor Adapter, Glass Filled Polypropylene (Black)	
5	CP50505-RYTON	Stem Bushing, Ryton (Black)	
*	6	CP7717-2-117-VI	O-Ring, Viton
7	CP50532-316SS	Stem, 316 Stainless Steel	
*	8	CP7717-M12X2.5-VI	O-Ring, Viton (2 Req'd)
9	CP50501-PP	Body, Glass Filled Polypropylene (Black)	
10	CP50507-304SS	Mounting Plate, 304 Stainless Steel	
*	11	CP50509-CTEF	Lower Bushing, Carbon Filled Teflon
12	CP50506-316SS	Ball, Polished 316 Stainless Steel	
*	13	CP50504-VI	Gasket, Viton
*	14	CP50503-CTEF	Seal, Carbon Filled Teflon
*	15	CP7717-2-223-VI	O-Ring, Viton
16	CP50502-PP	End Cap, Glass Filled Polypropylene (Black)	
AB356-KIT, Spare Parts Kit (Includes all items marked with *)			

■ Note: For Negatively Switched Motors Specify "N" rather than "P" in Motor Part Number
 Example: 50515-25CN05



DESCRIPTION:		 Spraying Systems Co.® Spray Nozzles and Accessories P.O. Box 7900 - Wheaton, IL 60187-7901
356BEC DIRECTOVALVE® ELECTRIC SHUT-OFF TRUNNION VALVE		
Rev. No. 6	PARTS LIST	
Ref. 3/13/2015	PL 356	
		SHEET OF