

UNIPILOT[®]

INSTALLATION MANUAL

Assisted Steering Kit Number 91-02400 or 91-02402



A Subsidiary of  Spraying Systems Co.[®]

Copyrights

© 2013 TeeJet Technologies. All rights reserved. No part of this document or the computer programs described in it may be reproduced, copied, photocopied, translated, or reduced in any form or by any means, electronic or machine readable, recording or otherwise, without prior written consent from TeeJet Technologies.

Trademarks

Unless otherwise noted, all other brand or product names are trademarks or registered trademarks of their respective companies or organizations.

Limitation of Liability

TEEJET TECHNOLOGIES PROVIDES THIS MATERIAL "AS IS" WITHOUT WARRANTY OF ANY KIND, EITHER EXPRESSED OR IMPLIED. NO COPYRIGHT LIABILITY OR PATENT IS ASSUMED. IN NO EVENT SHALL TEEJET TECHNOLOGIES BE LIABLE FOR ANY LOSS OF BUSINESS, LOSS OF PROFIT, LOSS OF USE OR DATA, INTERRUPTION OF BUSINESS, OR FOR INDIRECT, SPECIAL, INCIDENTAL, OR CONSEQUENTIAL DAMAGES OF ANY KIND, EVEN IF TEEJET TECHNOLOGIES HAS BEEN ADVISED OF SUCH DAMAGES ARISING FROM TEEJET TECHNOLOGIES SOFTWARE.

Table of Contents

PREPARATION	2
COMPONENTS	2
INSTALLATION	6
Overview of the Assembly	6
Six Simple Steps to Get Going!	7
Assemble Mounting Bracket	7
<i>Configuration Options</i>	8
UniPilot ESM	9
Assemble UniPilot ESM	9
<i>Disassemble UniPilot ESM</i>	9
Secure the Mounting Bracket	9
Electronics Connections	10
Connect SCM Harness	10
Install the System Ready Switch	10
Connect the Engage/Disengage Switch	10
General Recommended Electronics Installation	11
OPERATION	12
Standby Position (Inactive)	12
Operating Position (Active)	12
Activate UniPilot ESM	12
Begin Assisted Steering	12
<i>Deactivate UniPilot ESM</i>	12
APPENDIX	13
Specifications	13
Operation and Storage Conditions	14
Trouble Shooting	14
Contact Pressure	14
Replacement of Contact Wheel	15

PREPARATION

Before beginning the installation, thoroughly clean the steering wheel and steering column area.

Park the vehicle on a clean, level floor with adequate clearance to work around.

Do not attempt to loosen or attach any fittings while the engine is running.

Photos and illustrations may vary from the actual components provided. This may be due to different installation options, operation modes or production models.

Always try to use original parts. Built to the highest standards of safety and reliability, TeeJet Technologies parts are to be used for this system as others might jeopardize the safety and function of the system. TeeJet is not responsible for any redesign or adaptations of the UniPilot ESM. Any changes to the UniPilot ESM voids the company warranty. TeeJet Technologies supplies a set of mounting brackets that combined can create a variation of options for your specific vehicle. Not all vehicles have been addressed with these parts and modifications or additions to these parts may be needed to fit your specific vehicle.



Safety Information

TeeJet Technologies is not responsible for damage or physical harm caused by failure to adhere to the following safety requirements.

As the operator of the vehicle, you are responsible for its safe operation.

The UniPilot is not designed to replace the vehicle's operator.

Do not leave a vehicle while the UniPilot is engaged.

Be sure that the area around the vehicle is clear of people and obstacles before and during engagement.

The UniPilot is designed to support and improve efficiency while working in the field. The driver has full responsibility for the quality and work related results.

Disengage and put the UniPilot ESM (Electric Steering Motor) in the standby position before operating on public roads. Put the UniPilot ESM in the standby position when not in use to prevent accidental engagement or loss of vehicle control.

COMPONENTS

Unpack the installation kit and identify the required parts for your installation. Soome kits may not include all items listed.

Part Number	Description	Quantity
32-04040	Switch, Engage/Disengage FieldPilot.....	1
32-04057	Switch, System Ready, UniPilot.....	1
45-05381	Cable, 3 Pos. Battery 3.66 m w/15 Amp Fuses	1
45-05626	Cable, Power/CAN/RS232 Adapter to Conxall 8pg	1
45-07718	Harness, SCM Short.....	1
45-07727	Cable, SCM to UniPilot Electric Steering Motor (ESM)	1
45-08101	Terminator, CAN Male, WP as Shipped	1
78-08075	Steering Control Module (SCM), Pro	1
90-02806	Kit, UniPilot Assisted Steering System	1
28-01029	UniPilot Electric Steering Motor (ESM) (included in 90-02806 Kit)	1
28-01030	UniPilot Contact Wheel (included in 90-02806 Kit)	1
91-07015	Kit, UniPilot Universal Mounting Bracket (included in 90-02806 Kit).....	1
90-50013	Kit, Cable Tie Bundle (15).....	1
98-05284	Manual, Installation, UniPilot	1

Part #	Description	Illustration
32-04040	Switch, Engage/Disengage FieldPilot	
32-04057	Switch, System Ready, UniPilot	

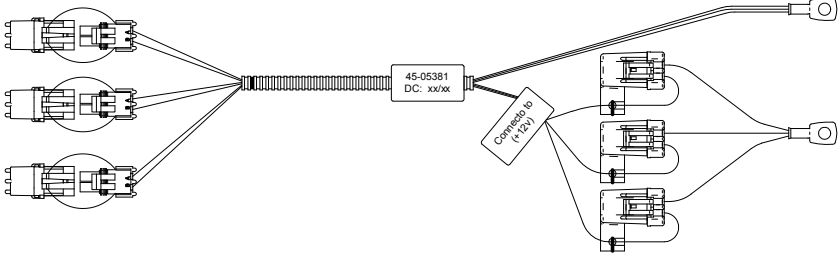
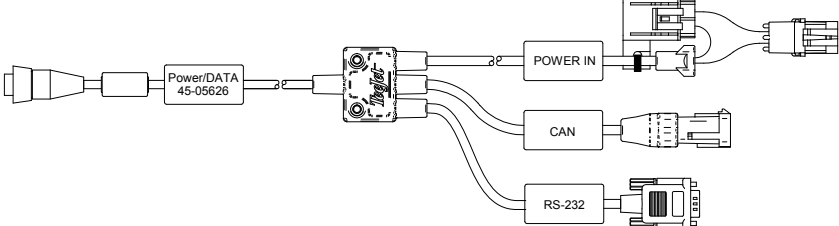
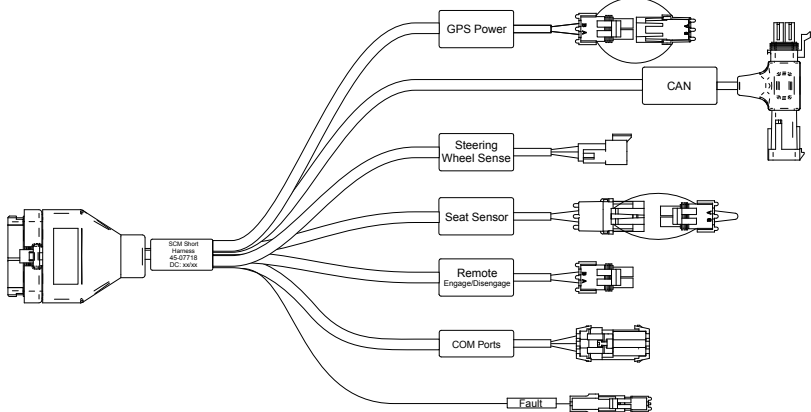
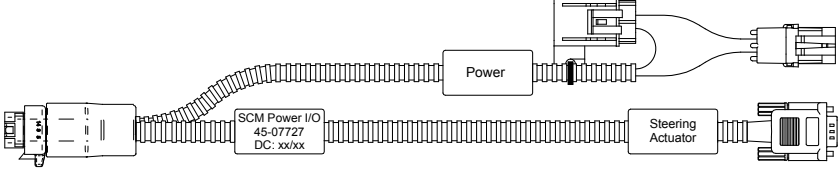
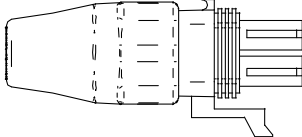
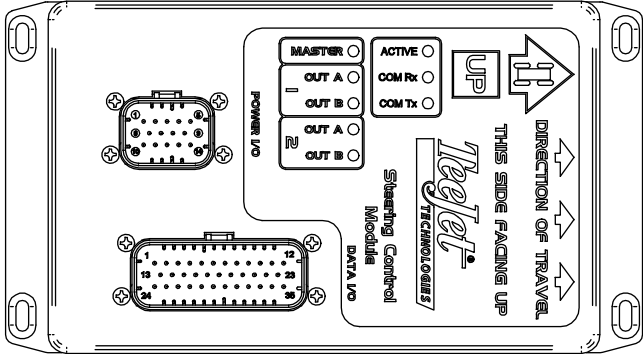
Part #	Description	Illustration
45-05381	Cable, 3 Pos. Battery 3.66 m w/15 Amp Fuses	
45-05626	Cable, Power/CAN/RS232 Adapter to Conxall 8pg	
45-07718	Harness, SCM Short	
45-07727	Cable, SCM to UniPilot ESM	
45-08101	Terminator, CAN Male, WP as Shipped	
78-08075	Steering Control Module (SCM), Pro	

Part #	Description	Illustration
90-02806	Kit, UniPilot Assisted Steering System	
28-01029	UniPilot Electric Steering Motor (ESM) (included in 90-02806 Kit)	
28-01030	UniPilot Contact Wheel (included in 90-02806 Kit)	
91-07015	Kit, UniPilot Universal Mounting Bracket (included in 90-02806 Kit)	

Figure 1-1: System Diagram



INSTALLATION

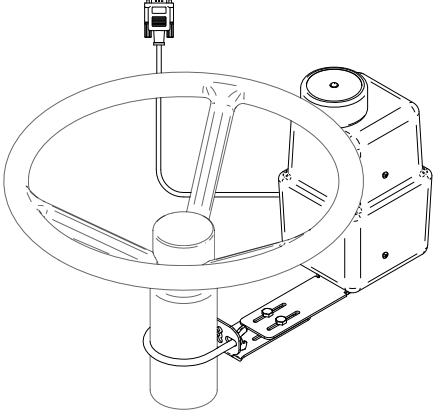
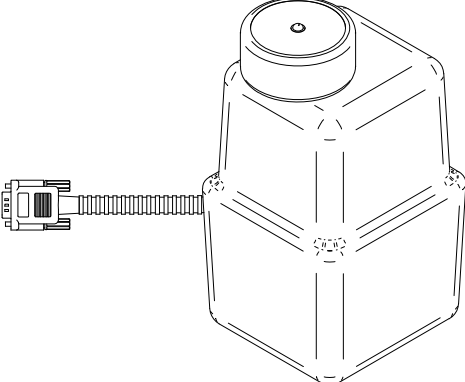
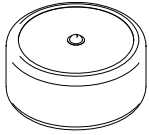
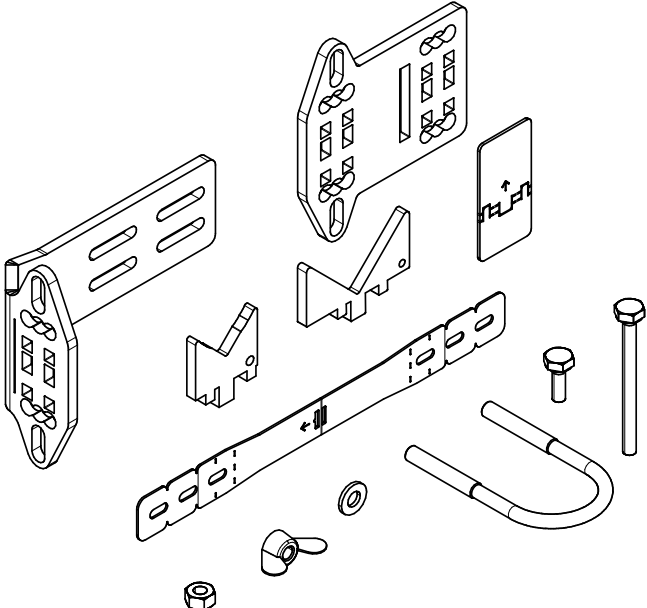
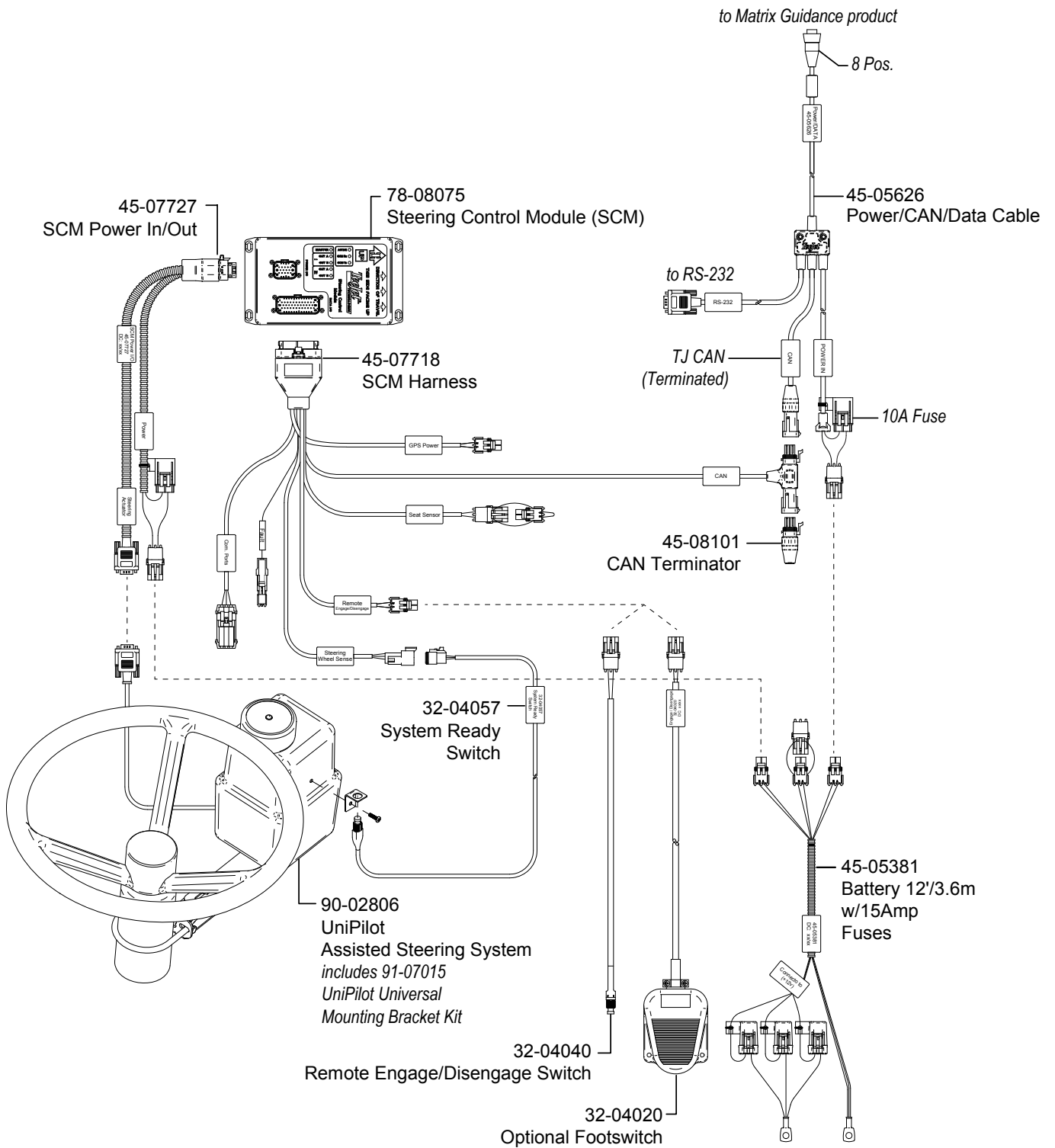

If there are questions concerning the installation of the UniPilot system on a vehicle, or due to the changes in component specifications the parts supplied in the kit are not as presented in this document, please contact your dealer or TeeJet Customer service representative for clarification before installation. TeeJet Technologies is not responsible for misuse or incorrect installation of the system.

NOTE: BE VERY CAREFUL TO ABSOLUTELY SECURE ALL CABLES SO THAT THEY DON'T INTERFERE WITH THE MANY MOVING PARTS OF THE UNIPILOT!

Overview of the Assembly

- The UniPilot will mount on the steering column of the machine.
- Installation of the mounting bracket does not require removing the steering wheel from the vehicle.
- Installation of the UniPilot does not prohibit movement of the steering wheel or a telescoping steering column.

Figure 1-2: Overview of the Machine

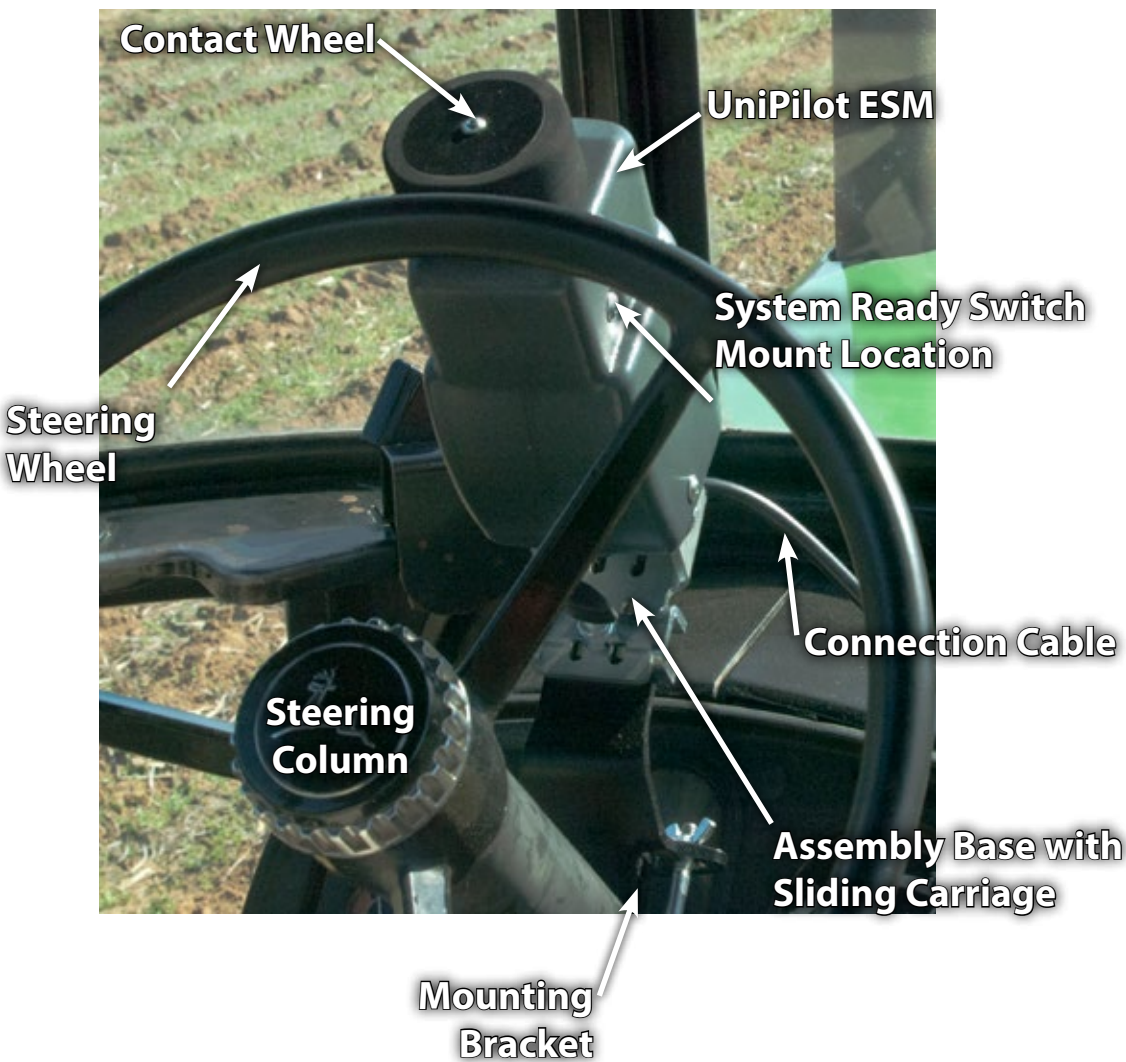

Six Simple Steps to Get Going!

1. Assemble Universal Mounting Bracket Kit on steering column so that it can be adjusted with the installation of the UniPilot ESM.
 - See page 8 for recommendations for your specific steering column.
2. Install UniPilot ESM and check spacing.
 - Attach the UniPilot ESM to the mounting bracket. The steering wheel should rotate freely around when the UniPilot ESM is in the Operating Position. When in the Standby Position, there should be 40 mm of space between the UniPilot contact wheel and the vehicle's steering wheel.
3. Secure or firmly tighten the mounting parts to Steering Column.
4. Connect Electronics.
5. Program Specific Settings on Guidance Console.
6. Activate & GO!

NOTE: All references to left and right are stated as if the user is seated in the driver's seat.

All references to front and back are stated in relationship to the front and back of the vehicle.

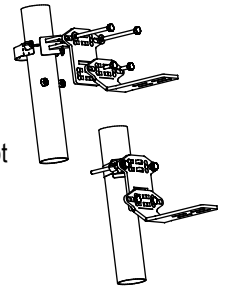
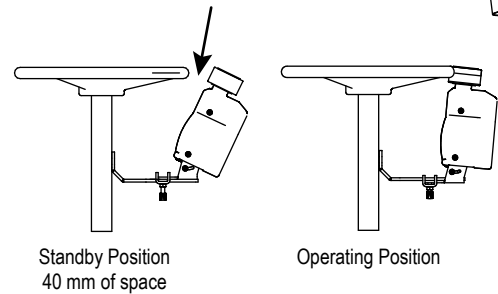

Assemble Mounting Bracket

The purpose of the mounting bracket is to securely mount the UniPilot ESM (Electric Steering Motor) to the steering column and keep the UniPilot ESM from rotating around the steering wheel.

Depending on the shape of your steering column, a different mounting bracket configuration may be needed. The following page illustrates a few examples of installation methods. If you do not see an example that illustrates your vehicle's requirements, please contact your dealer or TeeJet Customer service representative for clarification on your specific vehicle's installation.

1. Assemble Universal Mounting Bracket Kit on steering column so that it can be adjusted with the installation of the UniPilot ESM. The mounting bracket will be secured after the UniPilot ESM is assembled.

Figure 1-3: Mounting Bracket Parts

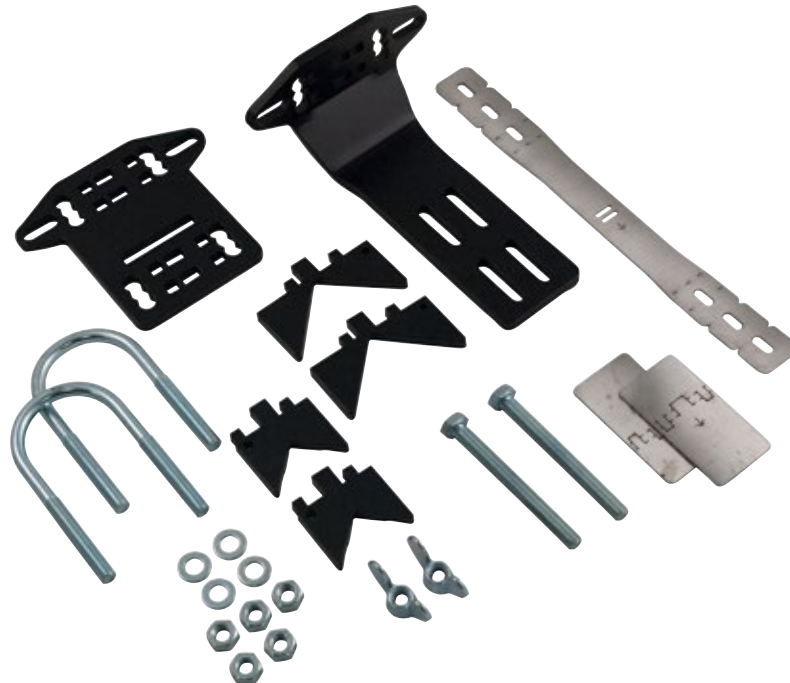

Configuration Options

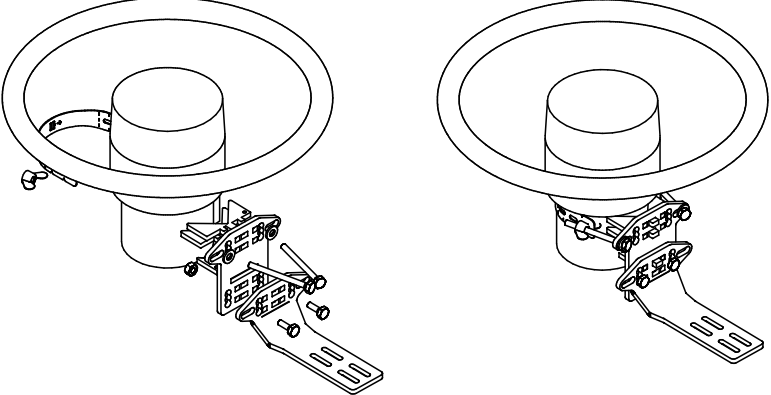
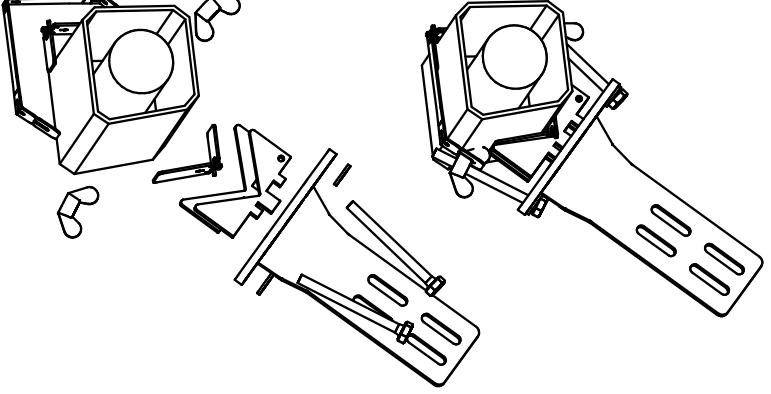
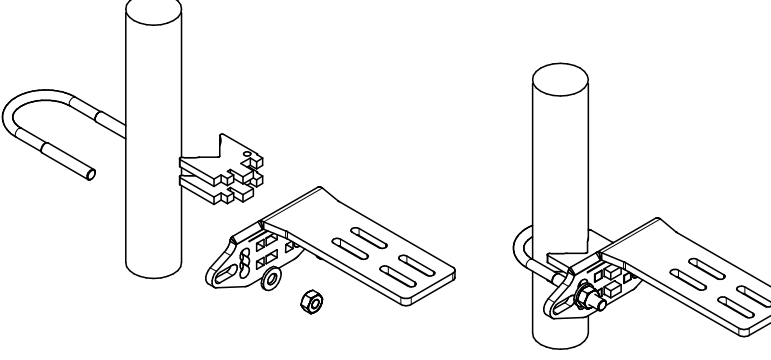
Installation Option	Type of Steering Column	Example <i>NOTE: The Mounting Bracket does NOT need to point up.</i>
<p>Metal Strap</p> <p>Use a metal strap to attach through the appropriate slots in the mounting bracket to steering wheel column and hand tighten loosely. Multiple slots have been made available to accommodate different steering column sizes.</p>	<p>Round</p>	
	<p>Square</p>	
<p>U-Bolts</p> <p>Use two (2) u-bolts, washers and nuts to attach mounting bracket to steering wheel column and hand tighten loosely.</p>	<p>Round, under 45 cm in diameter</p>	

UniPilot ESM

Assemble UniPilot ESM

1. Slip the sliding carriage onto the assembly base.
2. Slip the steering column bracket between assembly base and sliding carriage.
3. With the UniPilot ESM in the standby position (see page 12), position the UniPilot ESM a distance of 40 mm from the steering wheel.
4. Tighten the sliding carriage black T-bolt.

Figure 1-8: Positioning of UniPilot ESM

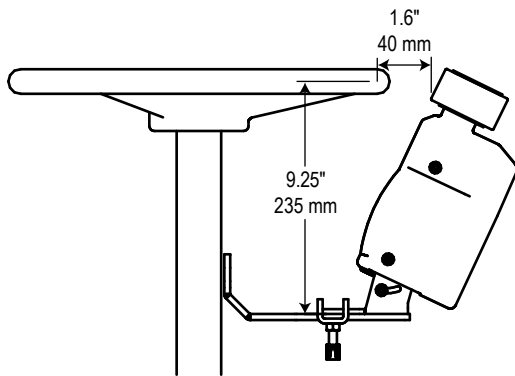

Figure 1-9: Positioning of UniPilot ESM



Disassemble UniPilot ESM

The disassembly of the steering motor UniPilot ESM happens in the reverse order of the assembly.

Secure the Mounting Bracket

Firmly tighten u-bolts, metal strap or other attachment device to the steering column to make sure that bracket(s) does not move when the steering wheel is rotated.

Make sure steering wheel freely rotates when the UniPilot ESM is in the operating position (see page 12).

HINT: Mark the ideal position of the UniPilot ESM on the steering wheel bracket to make the next vehicle change easier.

Figure 1-4: Insert UniPilot ESM Into Sliding Carriage

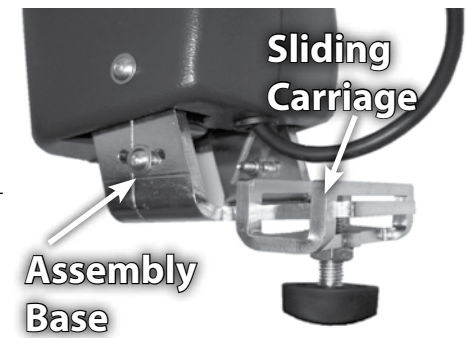

Figure 1-5: Slip UniPilot ESM Onto Mounting Bracket

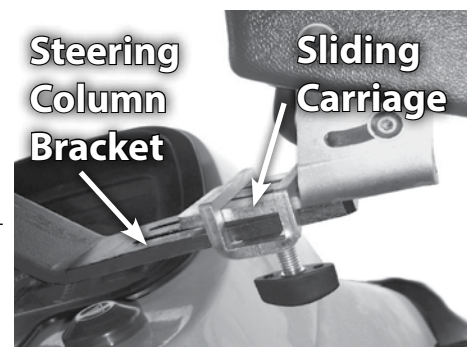

Figure 1-6: Tighten Sliding Carriage



Figure 1-7: Secure the Mounting Bracket



Electronics Connections

Connect SCM Harness

Connect UniPilot ESM to the Steering Control Module (SCM) through the SCM harness using the Steering Actuator connection.

Figure 1-10: Electronics Connection

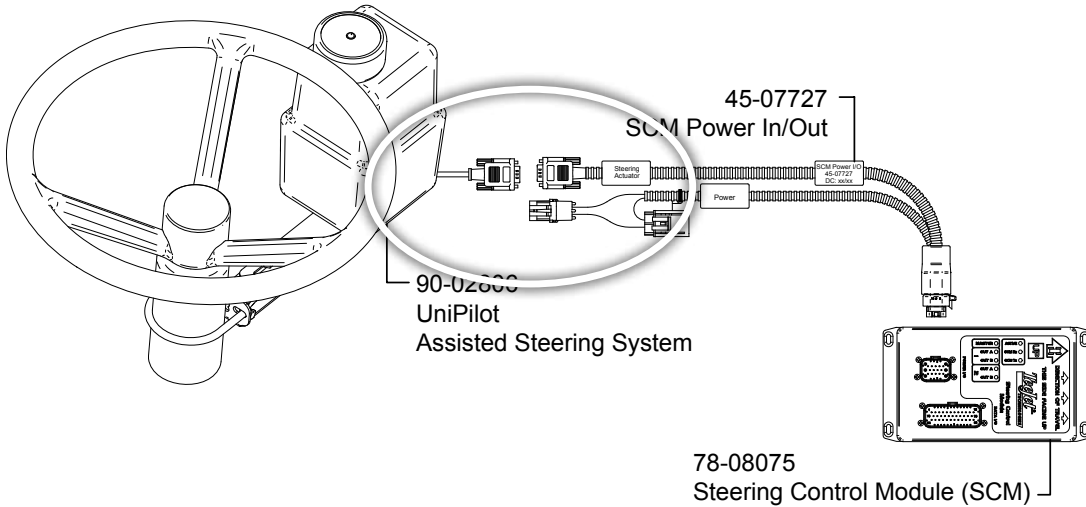

Install the System Ready Switch

1. Using a 3 mm allen wrench, remove the existing screw on either the top right or top left side of the UniPilot ESM.
2. Use the existing screw to mount the switch bracket using the small hole on the bracket.
3. Disassemble top nut and washer from System Ready Switch.
4. Slide detector button through large hole in bracket.
5. Hand tighten the washer and nut back on to the detector.

Figure 1-13: System Ready Switch



Figure 1-11: System Ready Switch Assembly

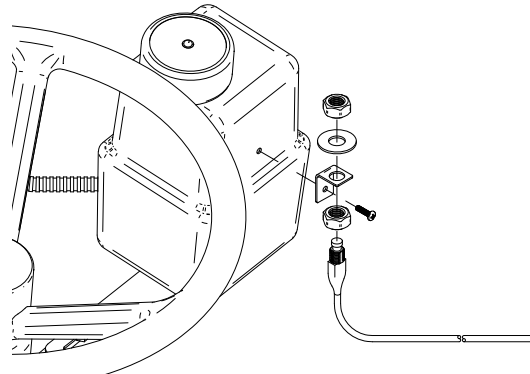
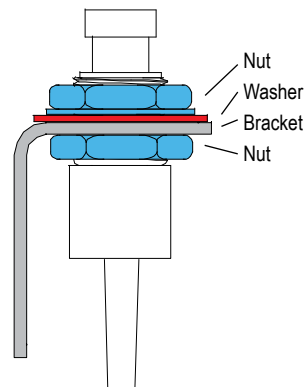

Figure 1-12: System Ready Switch Detail



Connect the Engage/Disengage Switch

Connect the Engage/Disengage Switch to the connector on the SCM harness labeled Remote Engage/Disengage. Install the push button in a location that is easily accessible during operation of the machine. This switch is not required if the optional foot switch 32-04020 is used.

General Recommended Electronics Installation

The Steering Control Module (SCM) must be mounted securely flat to the floor of the cab with the arrow facing forward. The control console can be mounted to the operator's preference. The GPS antenna should be mounted as far forward as possible on top of the cab or hood (depending on vehicle) on a metal surface of at least 10 cm square.

Figure 1-14: Recommended Electronics Installation



OPERATION

If there are questions concerning the operation of the UniPilot system on this vehicle, or due to the changes in component specifications the parts supplied in the kit are not exactly as presented in this document, please contact your dealer or TeeJet Customer service representative for clarification before operation. TeeJet Technologies is not responsible for misuse or incorrect operation of the system.

NOTE: BE VERY CAREFUL TO ABSOLUTELY SECURE ALL CABLES SO THAT THEY DON'T INTERFERE WITH THE MANY MOVING PARTS OF THE UNIPILOT!



WARNING! Disengage and put the UniPilot ESM in the standby position before operating on public roads.

Standby Position (Inactive)

To put the UniPilot ESM in the standby position, pull the contact wheel away from the steering wheel until the standby mechanism engages and the UniPilot ESM is not pulled in the direction to the steering wheel anymore.

Figure 1-15: UniPilot ESM in Standby Position



Operating Position (Active)

To bring the UniPilot ESM into its operating position, pull/push the contact wheel away from the steering wheel until the standby mechanism disengages and the UniPilot ESM is pulled in the direction to the steering wheel again. The UniPilot ESM is active and ready for action now.

Figure 1-16: Pull UniPilot ESM to Operation Position



Activate UniPilot ESM

With each power cycle of the guidance console, the UniPilot ESM will need to be activated.

1. Make sure the guidance console is on and has completed the start-up process.
2. Press the System Ready Switch 3 to 4 times to acknowledge the UniPilot ESM is in the operating position and ready.

Figure 1-17: System Ready Switch

Begin Assisted Steering

To begin using the UniPilot to assist with steering:

1. Make sure the UniPilot ESM is in the operating position.
2. While the vehicle is moving in a forward motion, press the Remote Engage/Disengage Switch or Footswitch.

NOTE: A guidance line must be established before the UniPilot can begin assist steering.



Deactivate UniPilot ESM

1. Press the remote Engage/Disengage Switch or Footswitch.

APPENDIX

Specifications

Connections		
RS232 9 position (Male)	1+2	Motor A
	3+4	Motor B
	5	n.c.
	6	Encoder + 10V
	7	Encoder GND
	8	Encoder Channel A
	9	Encoder Channel B
Length	0.5 m	

Motor	
Nominal Voltage	12 V
Nominal Torque	0.5 Nm
Nominal Speed	390 rpm
Nominal Current	2 A
Maximal Current	4.5 A
Starting Torque	2 Nm

Encoder	
Supply voltage	4.5 V– 26.5 V
Impulses	16 Imp / rev (open collector)

Dimensions / Mechanical	
Height	215 mm (260 mm) (with mounting bracket)
Width	90 mm
Depth	115 mm (145 mm) (with mounting bracket)
Weight	2900 g

Environmental	
Storage temperature	-40°C to 90°C
Operation temperature	-40°C to 80°C
Protection rating	IP 30
Chemical contamination	Water and aqueous saline solution Dilute acids and bases, Aliphatic hydrocarbons Herbal and animal fats and oils Ethanol Diesel Perspiration
Inflammability	Housing of low flammability according to UL 94 HB at d = 1,6 mm
Mechanical resistance	Rough handling on construction site (e.g. mortar, cement, lime, resistant against scratches and abrasion)
Drop	0.3 m to all surfaces 0.7 m to rubber mat in vehicle cabin

Values are subject to change without prior notice.

Operation and Storage Conditions

Electronic components of the UniPilot ESM are designed for rough environmental conditions like agricultural applications. However it should always be installed in the operator's station of the vehicle.

Warning! Never use a pressure washer to clean the UniPilot ESM. If needed wipe with a moist cloth.

Warning! Always protect the UniPilot ESM from falling onto a hard surface, to prevent internal damage.

Life expectancy of the UniPilot ESM can be extended by storing it under optimal conditions. Keep all mounting screws and brackets together if the motor is not installed in a stored vehicle. Avoid locations with high humidity as well as high temperatures near generators, radiators or near windows in direct sunlight.

Trouble Shooting

Description	Cause	Troubleshooting
UniPilot ESM does not turn	No signals from SCM (steering unit) to UniPilot ESM	Check steering system
	Open wire between steering system and UniPilot ESM	Check cable between steering system and UniPilot ESM
	Open wire between power supply and UniPilot ESM, UniPilot ESM is not supplied with voltage	Check power supply of UniPilot ESM
Contact wheel of UniPilot ESM slips on steering wheel	Spring force of collapsible mechanism of UniPilot ESM is too low	Check distance from contact wheel and stand by position. Once verified then adjust contact pressure as stated below.
		Increase spring force of collapsible mechanism of UniPilot ESM (see page 35 for details)
	Contact wheel of UniPilot ESM is worn	Replace contact wheel of UniPilot ESM (see page 36 for details)

Contact Pressure

Should the contact wheel slip while activating the steering wheel, the contact pressure needs to be increased. Either slide the UniPilot ESM towards the steering wheel or increase the spring preload.

To Increase / Decrease the Spring Preload:

1. Disassemble the UniPilot ESM.
2. Bring the motor to the normal operating position, so that the spring tension against the two mounting screws is at it's lowest.
3. Loosen the two mounting screws in the assembly base with a 2.5 mm allen wrench, if necessary hold the inside nut with a 8mm open end wrench.
4. To increase pressure move the two mounting screws with the spring ends in direction (1) To reduce pressure move the two mounting screws with the spring ends in direction (2).
5. Once you have the desired spring pressure tighten the two mounting screws.
6. Reassemble the UniPilot ESM to its mounting bracket on the steering column.

Figure 1-18: Loosen Mounting Bracket Screws

Figure 1-19: Increase/Decrease Spring Preload

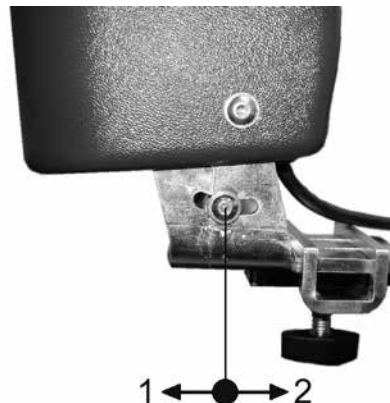

Replacement of Contact Wheel

The contact wheel is a wear part and has to be replaced when worn.

To replace the contact wheel:

1. Put the UniPilot ESM in the standby position.
2. Unscrew the cover mounting screw with a 3 mm allen wrench.
3. Remove the cover from the contact wheel.
4. Pull the wheel from the 4 holding pins.
5. Slip the new contact wheel onto the four holding bolts and press it down.
6. Replace the cover and hand tighten the holding screw.

Figure 1-20: Unscrew Cover



Figure 1-21: Remove Top Cover



Figure 1-22: Contact Wheel With Holding Pins



UNIPILOT®

INSTALLATION MANUAL

Six Simple Steps to Get Going!

1. Assemble Universal Mounting Bracket Kit on steering column so that it can be adjusted with the installation of the UniPilot ESM.
2. Install UniPilot ESM and check spacing.
 - Attach the UniPilot ESM to the mounting bracket. The steering wheel should rotate freely around when the UniPilot ESM is in the Operating Position. When in the Standby Position, there should be 40 mm of space between the UniPilot contact wheel and the vehicle's steering wheel.
3. Secure or firmly tighten the mounting parts to Steering Column.
4. Connect Electronics.
5. Program Specific Settings on Guidance Console.
6. Activate & GO!

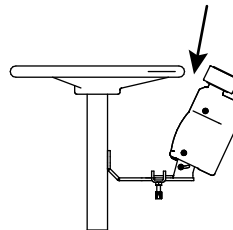
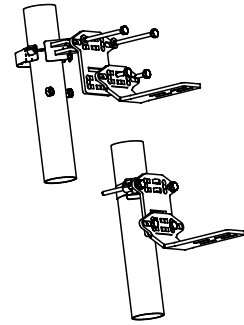

Standby Position
40 mm of space

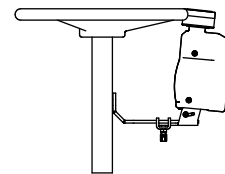

Operating Position

TeeJet®
TECHNOLOGIES

Mølhavevej 2
9440 Aabybro
Denmark
Tel: +45 9696 2500 • Fax: +45 9696 2501
www.teejet.com

A Subsidiary of  **Spraying Systems Co.®**

98-05226-EN R4 English/International
© TeeJet Technologies 2013

UNIPILOT®