

UNIPILOT® PRO

ELECTRIC STEERING DEVICE

Installation Manual



TeeJet®
TECHNOLOGIES

A Subsidiary of  Spraying Systems Co.®

Copyrights

© 2016 TeeJet Technologies. All rights reserved. No part of this document or the computer programs described in it may be reproduced, copied, photocopied, translated, or reduced in any form or by any means, electronic or machine readable, recording or otherwise, without prior written consent from TeeJet Technologies.

Trademarks

Unless otherwise noted, all other brand or product names are trademarks or registered trademarks of their respective companies or organizations.

Limitation of Liability

TEEJET TECHNOLOGIES PROVIDES THIS MATERIAL "AS IS" WITHOUT WARRANTY OF ANY KIND, EITHER EXPRESSED OR IMPLIED. NO COPYRIGHT LIABILITY OR PATENT IS ASSUMED. IN NO EVENT SHALL TEEJET TECHNOLOGIES BE LIABLE FOR ANY LOSS OF BUSINESS, LOSS OF PROFIT, LOSS OF USE OR DATA, INTERRUPTION OF BUSINESS, OR FOR INDIRECT, SPECIAL, INCIDENTAL, OR CONSEQUENTIAL DAMAGES OF ANY KIND, EVEN IF TEEJET TECHNOLOGIES HAS BEEN ADVISED OF SUCH DAMAGES ARISING FROM TEEJET TECHNOLOGIES SOFTWARE.

Table of Contents

IMPORTANT INFORMATION	II
Introduction.....	ii
Legal Disclaimer.....	ii
Safety Information	ii
Safety Instructions	ii
Warning Alerts.....	iii
Caution Alerts	iv
INSTALLATION REQUIREMENTS	IV
Standard Tool Requirements	iv
Vehicle Requirements	iv
Vehicle Inspection	iv
CHAPTER 1 - COMPONENTS	1
Supported Models	1
UniPilot Pro Main Hardware Kit	1
UniPilot Pro Switch Kit	2
CHAPTER 2 - UNIPILOT PRO INSTALLATION	3
INSTALL THE MAIN GEAR ON THE STEERING WHEEL	3
Install the Main Gear around the Steering Column	3
Examine Steering Column and Steering Wheel.....	4
ATTACH THE ANTI-ROTATION PIN	5
INSTALL THE ESD	6
CHAPTER 3 - UNIPILOT PRO ANTI-ROTATION BRACKET INSTALLATION	7
UniPilot Pro Anti-Rotation Bracket Installation Kit Overview	7
UniPilot Pro Anti-Rotation Bracket Installation Procedure	8
CHAPTER 4 - UNIPILOT PRO HARNESS INSTALLATION	9
Safety Notes.....	9
UniPilot Pro Harness Connections Overview.....	9
UniPilot Pro Harness Installation Procedure	10
CHAPTER 5 - ON/OFF SWITCH	11
On/Off Switch	11
Led Lights	11
CHAPTER 6 - CARE AND MAINTENANCE	12

IMPORTANT INFORMATION

Introduction

The ESD (Electric Steering Device) is a high performance steering actuator designed to provide high precision steering when coupled to a GNSS automated steering system. The ESD was designed for ease of installation, portability between vehicles and a long service life. The ESD uses a reliable high torque DC motor and a robust and simple gear drive for fast and responsive steering under all field steering conditions. The unique split gear design and quick-release latch makes for an easy installation that does not require the removal of the steering wheel so you gain time and are also able to easily transfer your ESD between vehicles.

This manual provides the basic information and overview of the installation procedure for installing the ESD steering actuator on a vehicle. The ESD can be installed on many makes, models, and types of vehicles. Read this manual prior to beginning the installation

as this manual provides the cautions and warnings that need to be recognized and understood prior to installing or operating a UniPilot Pro system.

This manual provides the instructions for the installation of the components that come with this UniPilot Pro installation kit. The installation is broken down into specific sections that may refer to sub-kit assemblies that are part of this kit. These sub-kits will come with their own instructions so refer to those when directed for information on installing the sub-kit parts.

Prior to operating the UniPilot Pro system, be sure to also read and understand the FieldPilot Pro & UniPilot Pro User Manual that comes with the UniPilot Pro system. That manual provides the instructions on how to operate the UniPilot Pro system with your guidance system as well additional safety information.

Legal Disclaimer

NOTE: Read and follow ALL instructions in this manual carefully before installing or operating the UniPilot Pro system.

NOTE: Take careful note of the safety information in the Safety Information section of this manual and the additional safety messages provided throughout this manual and any other supplemental material provided.

The manufacturer disclaims any liability for damage or injury that results from the failure to follow the instructions, cautions, and warnings set forth herein. Please take special note of the following warnings:

1. There is NO obstacle avoidance system included with the manufacturer's product. The owner must always have a human present in the operator's seat of the vehicle when the UniPilot Pro system is in use to look for obstacles including people, animals, trees, ditches, buildings, etc. and take control of the vehicle to manually avoid them if necessary.
2. The UniPilot Pro system does NOT control the speed of the vehicle. The operator must always adjust the speed of the vehicle manually so that it is operated at a safe speed that will not cause the vehicle to roll over or go out of control.
3. The UniPilot Pro system will take over control of the vehicle's steering system when the UniPilot Pro system is activated during: Testing, calibration, tuning, and automatic steering operations. The vehicle's steering axles, tracks, articulation point, or wheels may move unpredictably when activated. Prior to starting the vehicle and/or activating the UniPilot Pro system, verify that all people and obstacles are clear of the vehicle to prevent death, injury, or damage to property.
4. Use of the UniPilot Pro system is NOT permitted while the vehicle is on public roads or in public areas. Verify that the system is powered OFF before driving on roads or in public areas.

Safety Information

Safety Instructions

Read these safety instructions and the user's instructions thoroughly, and follow the instructions.

- Only an operator who is fully authorized to drive the tractor can make use of the UniPilot Pro system.
- The operator must not exceed the safe speed limit for the terrain it is operating on.
- An operator must always be conscious of his actions when operating the UniPilot Pro system.
- When installing the UniPilot Pro system do not force the components as this can result in the components being damaged.
- Always follow the instructions in the installation; operation; and maintenance manual.
- Only an authorized party should install the UniPilot Pro system.
- Always carry out an inventory of the components delivered to ensure all the correct components are present. Never use replacement components. Only use original components.
- If there are any questions regarding the safe operation of the UniPilot Pro system or the instructions in the manuals do not hesitate to always contact the responsible expert.
- Always use the correct tools to install the UniPilot Pro system.
- Caution must be taken when installing the UniPilot Pro system to prevent injury.
- Do not use or operate the UniPilot Pro system in unsafe weather conditions. Do not use or operate the UniPilot Pro system if the terrain is unsafe.

- It is not allowed for an unauthorized person to use or operate the UniPilot Pro system.
- Before starting work activities, the operator must have sufficient knowledge of procedures how operate the UniPilot Pro system in a safe manner.
- When installing the UniPilot Pro system, all safety precautions must be taken into account and it should not be used if there are any parts loose, missing or damaged.
- Only an operator who has been trained or is experienced may operate the UniPilot Pro system.
- Before using the UniPilot Pro system all functions must be checked and controlled for their correct working order. When there is any doubt, do not take any risks always consult an expert.
- Before operating the UniPilot Pro system, control all functions of the Presence Switch and confirm the settings to ensure it functions correctly.
- Turning the UniPilot Pro system on and off must always happen consciously following the correct prescribed procedures.
- If an abnormal phenomenon presents itself, for example excessive vibrations or noise, then immediately turn off the UniPilot Pro system and consult a responsible expert.
- When the UniPilot Pro system is being cleaned or when maintenance takes place, it must be totally turned off and free of any electrical currents.
- The operator of the UniPilot Pro system must have complete knowledge about how to react in case of emergency.
- A trained expert must always carry out maintenance or repairs on the UniPilot Pro system.
- During repair or replacement of components on the UniPilot Pro system only original components must be used.
- Always wear correct prescribed personal protection equipment during the use or cleaning or maintenance of the UniPilot Pro system.
- Always use the recommended cleaning materials and accessories when the UniPilot Pro system is cleaned.
- Every unsafe condition or situation on the UniPilot Pro system must be reported to the responsible persons.
- Do not leave or place objects on or in the area of the UniPilot Pro system.

Warning Alerts

The UniPilot Pro system installer and manufacturer disclaim any responsibility for damage or physical harm caused by the failure to adhere to the following safety requirements:

- As the operator of the vehicle, you are responsible for its safe operation.
- The steering system is not designed to replace the vehicle's operator.

NOTE: After the installation of the UniPilot Pro system, verify that all the screws, bolts, nuts, and cable connections are tight. Verify that all the cables have been secured to prevent them from being damaged.

WARNING: To understand the potential hazards associated with the operation of a ESD equipped vehicle, read the provided documentation prior to installing or operating the UniPilot Pro system.

WARNING: To prevent accidental death or injury from being run over by the vehicle or automated motion of the steering system, never leave the vehicle's operator seat with the UniPilot Pro system engaged.

WARNING: Movement of the Steering Control Module (SCM Pro) relative to the vehicle may cause erratic steering and sudden loss of vehicle control while in AutoSteer mode. Always keep the Steering Control Module (SCM Pro) firmly secured to the vehicle. Do not operate your UniPilot Pro system with a loose SCM Pro.

WARNING: To prevent accidental death or injury from being run over by the vehicle verify that area around the vehicle is clear of people and obstacles before startup, calibration, tuning, or use of the UniPilot Pro system.

WARNING: To prevent the accidental engagement of the UniPilot Pro system and loss of vehicle control while driving on roads, turn the ESD power switch to the OFF position or remove the ESD from the steering column. Never drive on roads or in public areas with the UniPilot Pro system powered up.

WARNING: The UniPilot Pro system is solely intended for agricultural use. The systems should only be used with agricultural vehicles and should not be used with any other type of vehicle or for any other purposes. Unapproved applications may result in loss of vehicle control resulting in injury or death.

Caution Alerts

The UniPilot Pro system installer and manufacturer disclaim any responsibility for damage or physical harm caused by the failure to adhere to the following safety requirements:

CAUTION: The UniPilot Pro system does not detect obstacles in the vehicle's path. The vehicle operator must observe the path being driven and take over steering manually if an obstacle must be avoided.

CAUTION: The UniPilot Pro system does not control the speed of the vehicle. The operator must manually adjust the speed of the vehicle to keep the vehicle safely under control.

CAUTION: To avoid possible damage to electronic circuits caused by electrostatic discharge, never touch the contacts on the SCM Pro electrical connectors at any time.

CAUTION: Make sure the assembly does not interfere with any of the vehicle control levers on the steering column.

CAUTION: Make sure that the main gear race has properly engaged on the three rollers before closing latch. If the race is not engaged properly, you risk damaging the ESD and steering wheel while the UniPilot Pro system is operating.

INSTALLATION REQUIREMENTS

Standard Tool Requirements

The installer is assumed to have a complete set of common installation tools including:

- 7/64" Allen Wrench
- 5/32" Allen Wrench
- 1/4" Open Wrench
- 1/4" Nut Driver
- Torque wrench 0 to 20 lb-in (0 to 2 Nm), for 5/32" hex bit

Vehicle Requirements

Prior to installing the UniPilot Pro system, verify the following items on the vehicle:

- The vehicle's steering system is in good working order. Drive the vehicle to verify this prior to beginning the installation. There should be no play in the steering and the vehicle should turn proportionally the same to the left and right.
- The vehicle's electrical system and battery must be in good working order.
- The vehicle should be fully cleaned before installing the UniPilot Pro system. A clean vehicle will improve the overall installation and cable routing.

If any issues are discovered with the vehicle, they must be repaired prior to beginning the UniPilot Pro installation by a qualified service person for the vehicle.

NOTE: This installation manual, vehicle specific installation manuals, and sub-kit manuals contains valuable information for servicing the UniPilot Pro system. After the installation is complete, store all of these manuals in a safe place for future reference.

Vehicle Inspection

Prior to installing the UniPilot Pro system, confirm that the vehicle and the vehicle's steering system are in good working order by driving it around. In addition, verify the following items:

- Verify that you can turn the steered wheels from lock to lock.
- Verify that there are no oil leaks.
- Verify the vehicle steers straight and does not pull to one side when driving in a straight line.
- Check for loose or worn steering components.

If any part of the vehicle is not in working order, have the system serviced by a qualified technician prior to beginning the UniPilot Pro installation procedure.

CHAPTER 1 – COMPONENTS

Supported Models

These instructions provide the suggested procedure for installing the UniPilot Pro system on qualified vehicles for the easiest installation and best performance. This product is compatible with most vehicles with a three spoke steering wheel with hydrostatic power steering.

NOTE: The installer can install the UniPilot Pro system differently than how the manufacturer suggests; however the components that are called out in this manual may not fit properly or the lengths of cables may not be long enough with alternative mounting solutions. If the installer modifies the installation procedure, it is the responsibility of the installer to ensure all the components will work and that any component with specific orientation and mounting requirements are met.

UniPilot Pro Main Hardware Kit

NOTE: The kits listed below are used for illustrations purposes. Hardware Kit part numbers will vary.

This section describes the UniPilot Pro components required for a typical installation. The installation kit is organized into a main kit that contains a “switch kit” subassembly. The Switch Kit contains the hardware that enables you to switch the UniPilot Pro system between vehicles.

The UniPilot Pro installation may require the components listed below.

Figure 1: ESD Kit

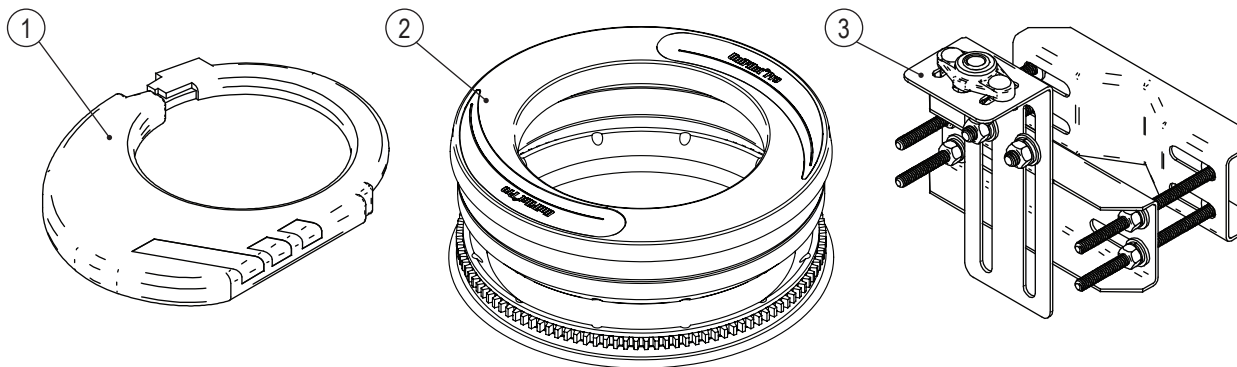

Table 1: ESD Kit

Item	Part #	Description	Qty
1	91-05023	Electric Steering Device, UniPilot Pro	1
2	91-05024	Switch Kit, UniPilot Pro	1
3	65-05246	UniPilot Pro Anti-rotation Bracket Kit	1
	65-05250	Assy. Anti-Rotation Pin UniPilot Pro	
	98-05342	UniPilot Pro Installation Guide	1

The sub-kits that are required for the installation of the UniPilot Pro system are provided in this section. Use this section to verify that all the sub-kits and parts required for the installation are available.

NOTE: All part numbers provided in this manual are subject to change without notice. They are provided as a reference at the time of this writing. Always verify that the part numbers are still valid from your UniPilot Pro dealer if spare parts need to be ordered.

UniPilot Pro Switch Kit

The Switch Kit components enable the operator to move the ESD between vehicles.

NOTE: An anti-rotation bracket that fits your vehicle steering column is required to complete the UniPilot Pro installation. This bracket varies by vehicle model and must be purchased separately. Contact your UniPilot Pro dealer for a list of supported vehicles and available bracket kits.

Figure 2: UniPilot Pro Switch Kit Components

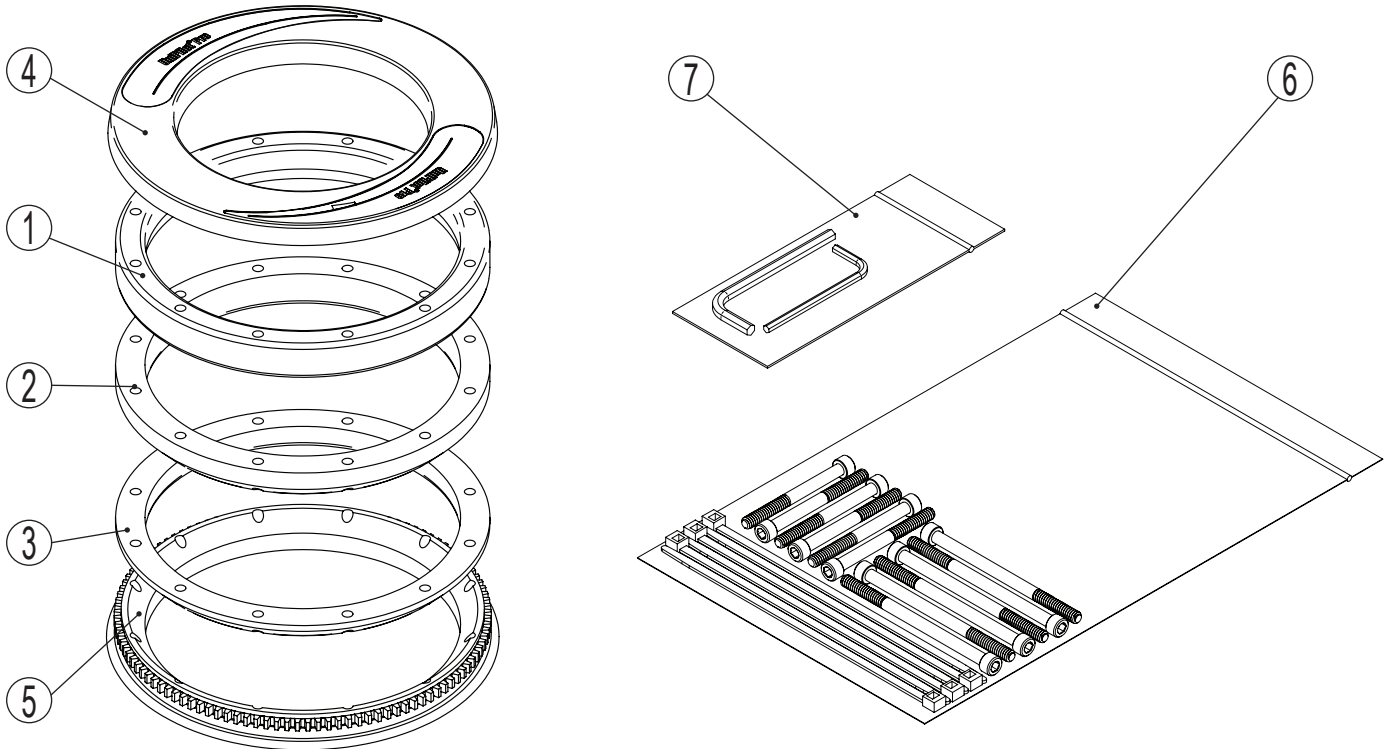

UniPilot Pro Switch Kit

Item	Part #	Description	Qty
1	402-0019-02	Upper Ring	1
2	402-0024-03	5.75 x 0.50 Spacer	1
3	402-0024-04	5.75 ID x 0.25 Spacer	1
4	Consult Dealer	Ring Cap Assembly	1
5	200-0621-01	Main Gear Assembly	1
6	200-0635-01	Hardware Kit	1
7	808-0015-01 808-0039-01	Hex Keys (5/32" & 7/64")	1

NOTE: All part numbers provided in this manual are subject to change without notice. They are provided as a reference at the time of this writing. Always verify that the part numbers are still valid from your UniPilot Pro dealer if spare parts need to be ordered.

CHAPTER 2 – UNIPILOT PRO INSTALLATION

The UniPilot Pro installation process is described below. A detailed process for each step is described in the following sections.

1. Install the Main Gear on the steering wheel
2. Attach the Anti-rotation Pin
3. Install the ESD

Refer to Installation Kit Components in the Components section to identify the parts used in this section.

INSTALL THE MAIN GEAR ON THE STEERING WHEEL

The goal of this section is the installation of the main gear on the steering wheel. Through the use of switch kits, main gears can be installed and left on multiple vehicles allowing the user to move the ESD.

Install the Main Gear around the Steering Column

1. Remove the 2 hex screws from the Smaller section of the Main Gear.
3. Install the larger section under the steering wheel around the steering column. Install with the gear side on the top side, closest to the steering wheel.

Figure 3: Main Gear Hex Screws

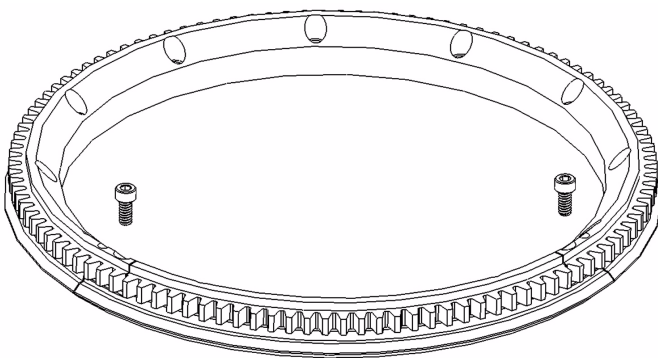

2. Remove the Smaller section by pulling downwards.

NOTE: Tolerances are tight, pull directly downwards on the smaller section.

Figure 4: Main Gear Smaller Section

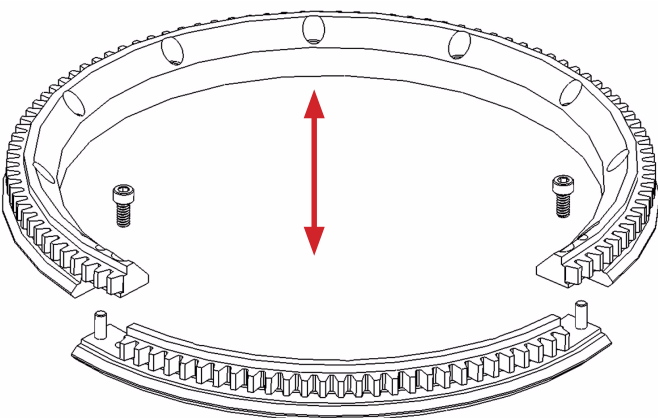

NOTE: Weave the gear around the steering wheel spokes if necessary, certain columns may be too thick for the gear opening.

Figure 5: Main Gear Installed

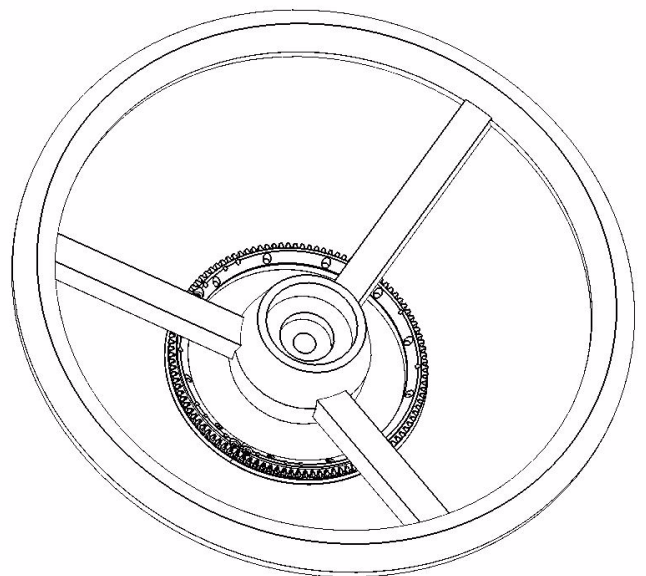

4. Reinstall the smaller section using care to push directly upwards on the sector, this is a very tight fit.

NOTE: To facilitate the fit between the two gear sections, you may need to apply a drop of oil to assist in aligning the two gear sections.

5. Reinstall and secure the 2 hex screws. At this point the main gear is assembled around the steering column below the steering wheel. The gear is free to move around and must now be clamped to the steering wheel.

Examine Steering Column and Steering Wheel

Examine the steering wheel underside to determine if a spacer is necessary. A steering wheel with a soft covering material usually requires installation of a spacer to avoid interference with the ESD housing. Flat steering wheels also require the addition of a spacer to prevent interference between the steering wheel and ESD when the wheel is turned.

Install Spacer (If Needed)

Install the spacer around the steering column between the steering wheel and the main gear. Flex the plastic spacer as needed to clear the steering wheel spokes. The large chamfer on the outside diameter of the spacer ring should be facing the main gear.

NOTE: Two spacers with different thicknesses are included in the kit. Select the thinnest spacer that provides the sufficient clearance between the steering wheel and the ESD.

Figure 6: Installing Spacers - Line up angles

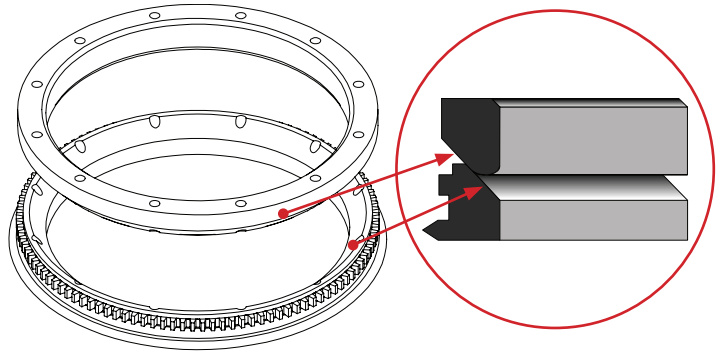

Figure 7: Spacer Installation



Install the Clamp Ring

1. The gear is free to move around and must be now clamped to the steering wheel. This procedure will install and center the ring gear for typical 3 spoke shaped steering wheels.
2. Place the clamp ring on top of the steering wheel and install a minimum of 6 hex screws. Install a screw on each side of every spoke keeping the screws as close to the spokes as possible. At this stage keep the screws fairly loose to allow for centering.

NOTE: Two lengths of screws are provided in the kit to support different thicknesses of the steering wheel spokes. Select the shorter of the two screws that still provides full thread engagement.

3. With the main gear clamped loosely, rotate and move the gear until 3 screws touch the three spokes evenly. Figure 9 shows the main gear rotated counter-clockwise until three of the mounting screws touch the steering wheel spokes evenly. This procedure will help to automatically center the gear under the steering wheel.

Figure 8: Installing Top Ring

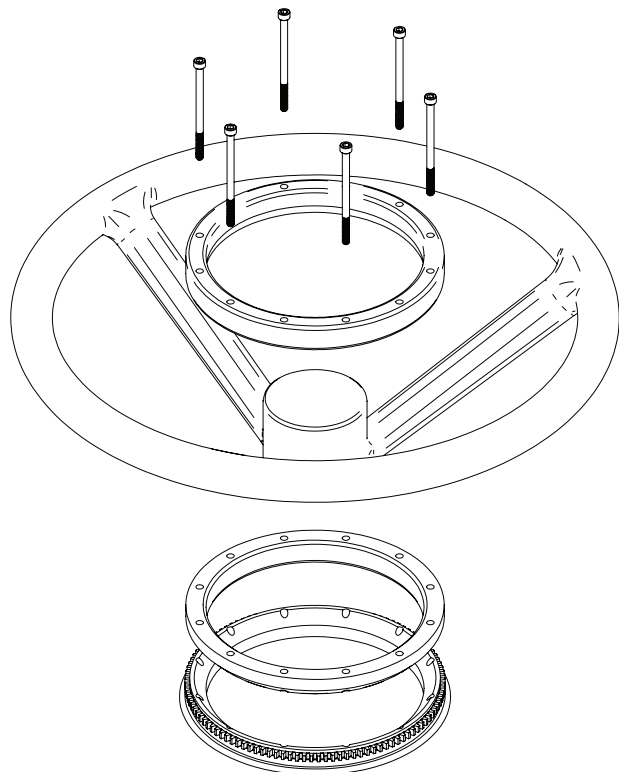
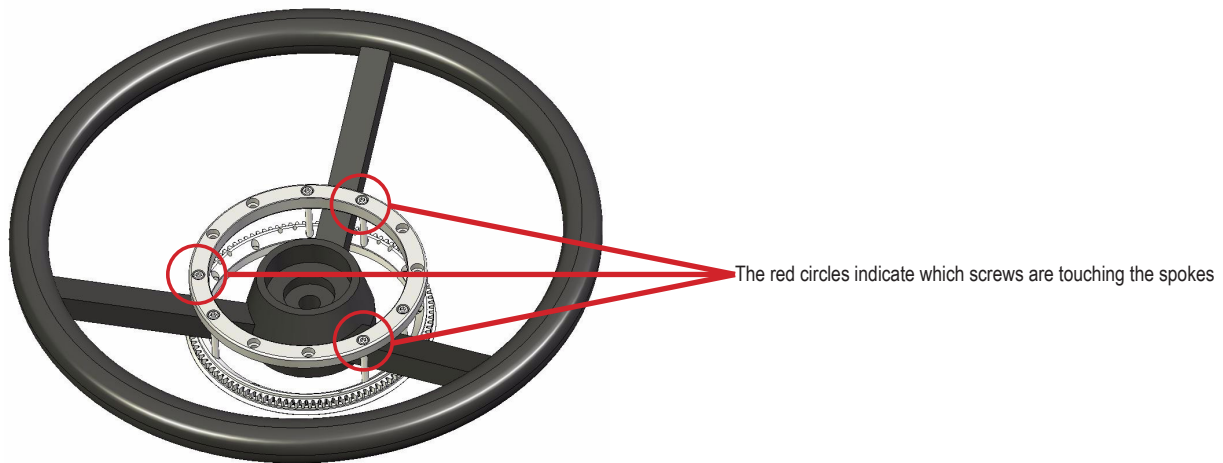

Figure 9: Centering Ring Gear



4. Check the installation by rotating the steering wheel and watching for off-center movement of the main gear. Repeat the centering process as necessary.
5. Tighten the screws with an Allen key. Torque to 6 in-lb (0.7 Nm). Tighten the screws in a cross-pattern (as opposed to tightening each screw in a clockwise or counter-clockwise order).

NOTE: Do not over-tighten the clamp ring screws. This may cause the ring gear to warp or damage the steering wheel spokes.
6. Check the installation again after tightening by rotating the steering wheel and watching for off-center movement of the main gear. Repeat the centering process as necessary.
7. Snap the plastic cover over the top ring.

Figure 10: Installing Plastic Cover

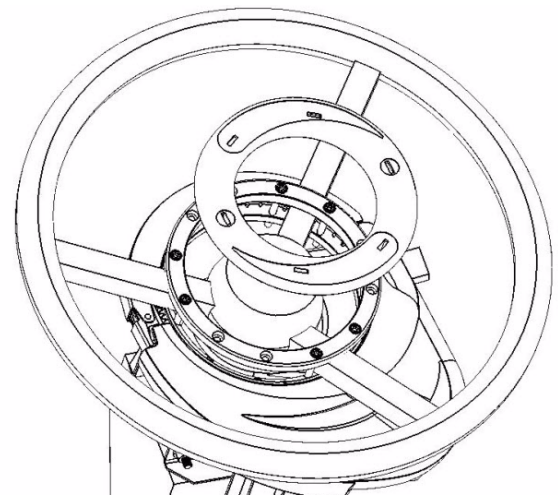

ATTACH THE ANTI-ROTATION PIN

1. Choose the desired ESD orientation. The ESD can be mounted in any orientation the user chooses. Consider the following when choosing an orientation:
 - Ease of installing anti-rotation bracket.
 - Access to the Power Switch.
 - Avoid locations where a knee could accidentally press the power switch.
 - Avoid blocking the vehicle's steering column controls and indicators.
 - Cable routing with minimal obstruction in the cab.
2. Based on your preferred orientation, choose one of three locations for the Anti-rotation Pin.

Figure 11: Anti-rotation Pin Kit

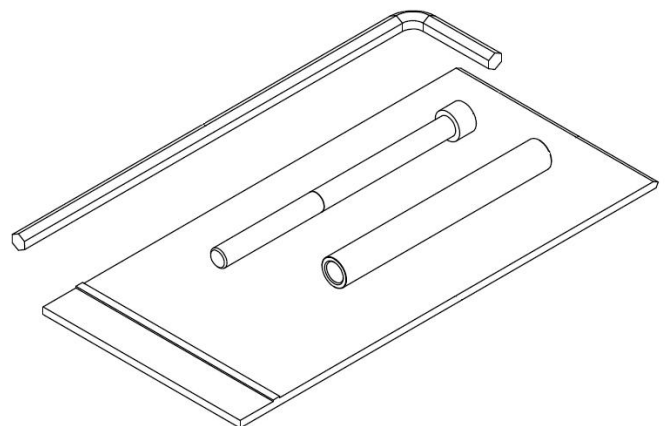
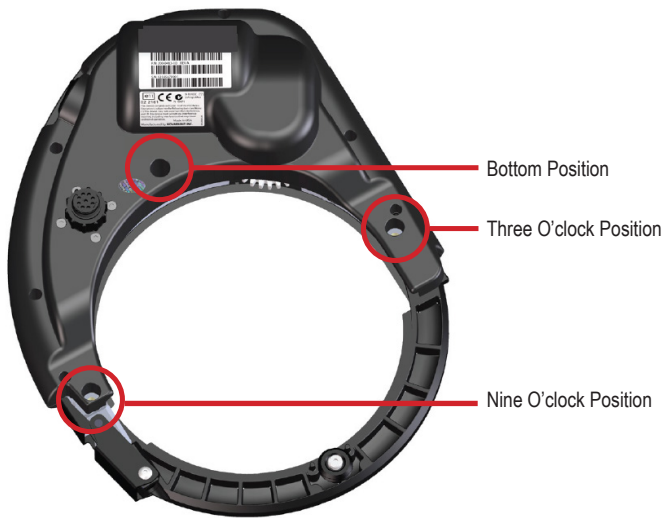

Figure 12: Anti-rotation Pin Locations



3. Assemble the anti-rotation pin by inserting the long screw through the metal sleeve provided.
4. Install the anti-rotation pin under the ESD in one of the three positions and tighten to 100 in.lbs (11.3 Nm) using the 3/16" hex key (Allen key) provided.

NOTE: The anti-rotation pin must always be kept tight to avoid breakage or separation. Periodically check the anti-rotation pin and confirm that it is tight. Always tighten to the specified torque.

INSTALL THE ESD

This procedure describes the installation of the ESD to the Main Gear

1. Open the ESD release latch.

Figure 13: Release latch

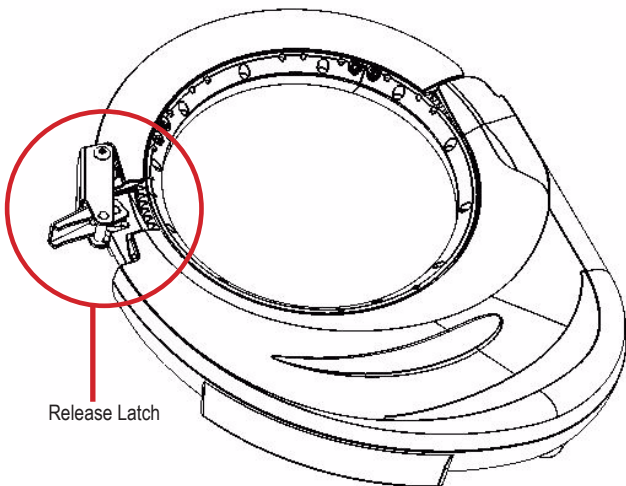

2. Fit the ESD around the Main Gear so that the three ESD rollers align on the Main Gear race.

NOTE: The plastic cover on the ESD can be used as a guide to fit the bottom portion of the ESD to the V-rollers.

Figure 14: Roller Engagement

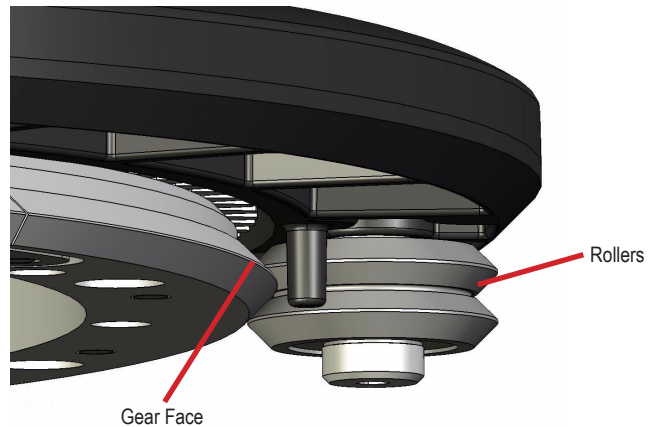

3. Ensure that the main gear race has properly engaged the three rollers before closing latch.
4. Rotate the ESD manually to ensure smooth rolling operation.

CHAPTER 3 – UNIPILOT PRO ANTI-ROTATION BRACKET INSTALLATION

The UniPilot Pro anti-rotation bracket is available through your dealer. It should be used for vehicles that are not supported with a custom vehicle-specific bracket. Consult your UniPilot Pro dealer for a list of all available anti-rotation brackets. An Anti-rotation bracket is required to complete the UniPilot Pro installation.

NOTE: A different bracket may be required depending on your specific vehicle. Contact your UniPilot Pro dealer for details.

NOTE: If you are installing a custom specific vehicle anti-rotation bracket, skip this section and refer to the instruction manual provided with your vehicle specific anti-rotation bracket kit.

UniPilot Pro Anti-Rotation Bracket Installation Kit Overview

To complete your UniPilot Pro installation and prevent the rotation of the ESD (Electric Steering Device), an anti-rotation bracket must be mounted to the vehicle steering column just below the steering wheel. This chapter provides instructions for installing a universal bracket kit that is available as an accessory through your FieldPilot Pro & UniPilot Pro dealer. Many other brackets are available to fit specific vehicles models and can be ordered through your FieldPilot Pro & UniPilot Pro dealer. Contact your dealer for details and availability for your vehicle model.

The Typical universal bracket kit includes the components.

Figure 15: Typical Universal Bracket Kit

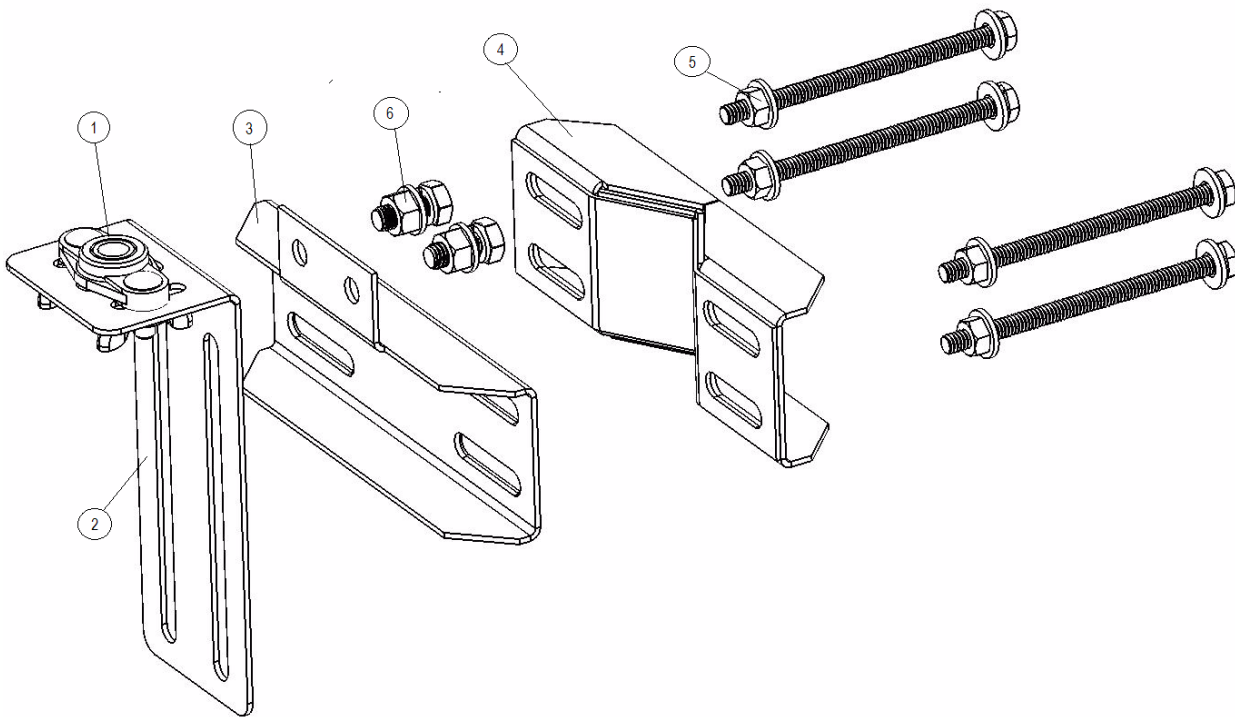

Table 2: Universal bracket kit components

Item	Part #	Description	Qty
1	522-0001-01	Flange Bearing	1
2	203-0218-01	Fifth Wheel Slider	1
3	202-0216-01	Front Bracket	1
4	202-0232-01	Back Bracket ("V" shape)	1
5	514-0088-01	Clamping screws. Machine Screw Phillips 1/4 - 20 x 4" (Washers, Lock Washers and Nuts)	4
6	512-0029-01	Bolts 5/16 -18 x 3/4" (Slider Attaching Bolts)	2

UniPilot Pro Anti-Rotation Bracket Installation Procedure

NOTE: The ESD is attached to the steering wheel prior to installation of the bracket kit.

1. Make sure that you have all of the required parts. Figure 15
2. Attach front bracket to the fifth wheel slider bracket using the two bolts (slider attaching bolts). Tighten finger tight.

NOTE: The slider bracket will require adjustment once installed on the steering column.

Figure 16: Slider Attachment Bolts

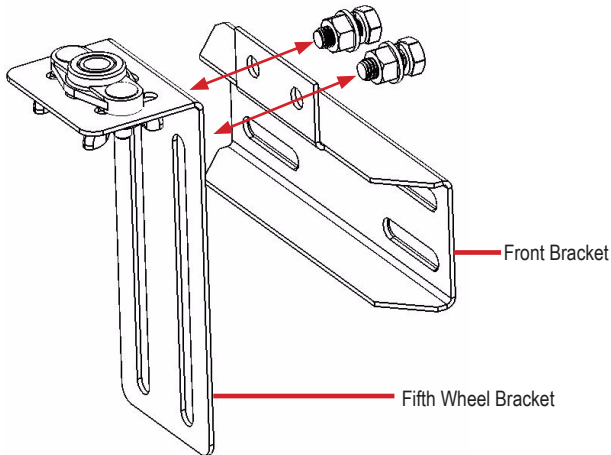

3. Place the flange bearing assembly over anti-rotation pin.

NOTE: It is important that the anti-rotation pin is placed through the flange bearing before attaching the Fifth Wheel Bracket

Figure 17: Anti-rotation Pin Engagement

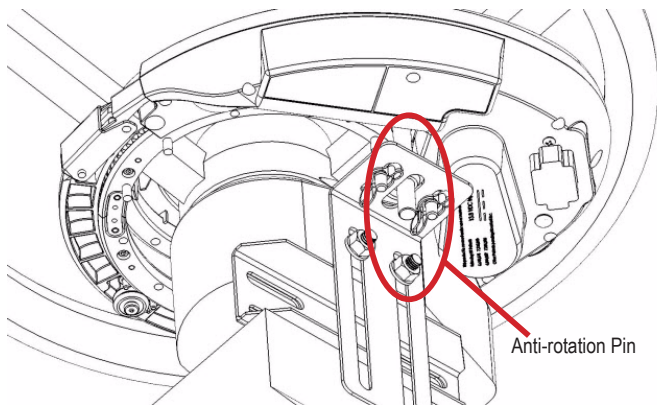

4. Attach the back bracket to the front bracket using the four machine screws clamping the steering column between the front and back brackets.

Figure 18: Back Bracket Installation

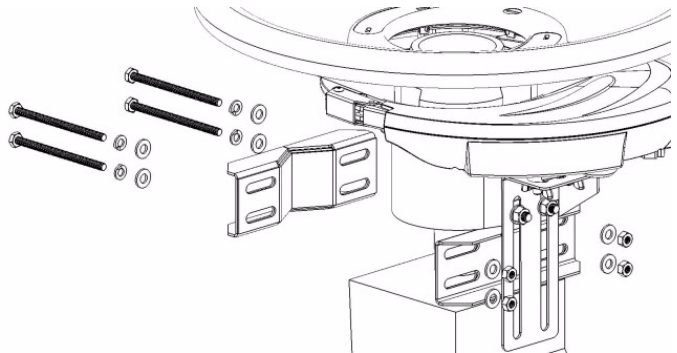

5. Tighten the clamping assembly.
6. Adjust the position of the fifth wheel slider so the flange bearing is approximately in the middle of the anti-rotation pin and tighten the bolts (Slider attaching bolts).

Figure 19: Slider Bracket Engagement

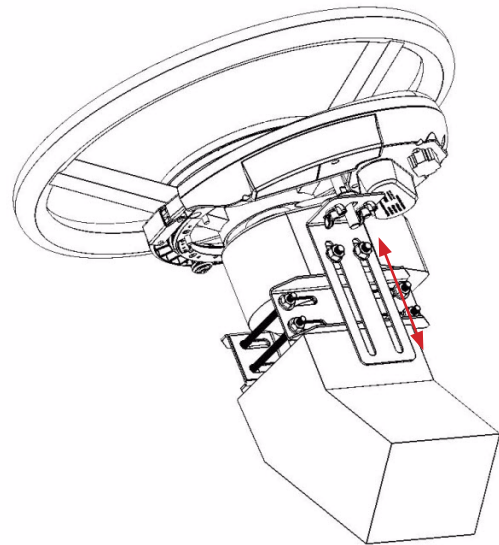

7. The bracket installation is complete.

CHAPTER 4 – UNIPILOT PRO HARNESS INSTALLATION

Safety Notes

NOTE: The vehicle must be powered off during the installation of UniPilot Pro harness

NOTE: To prevent the system from any unexpected shut down while operating, check the cable insulation and cable connections to the other instruments. Route the cables away from all sharp edges to prevent control wires from being pulled hard or damaged.

UniPilot Pro Harness Connections Overview

The typical UniPilot Pro Harness installation includes the components shown below.

Figure 20: UniPilot Pro Harness Components

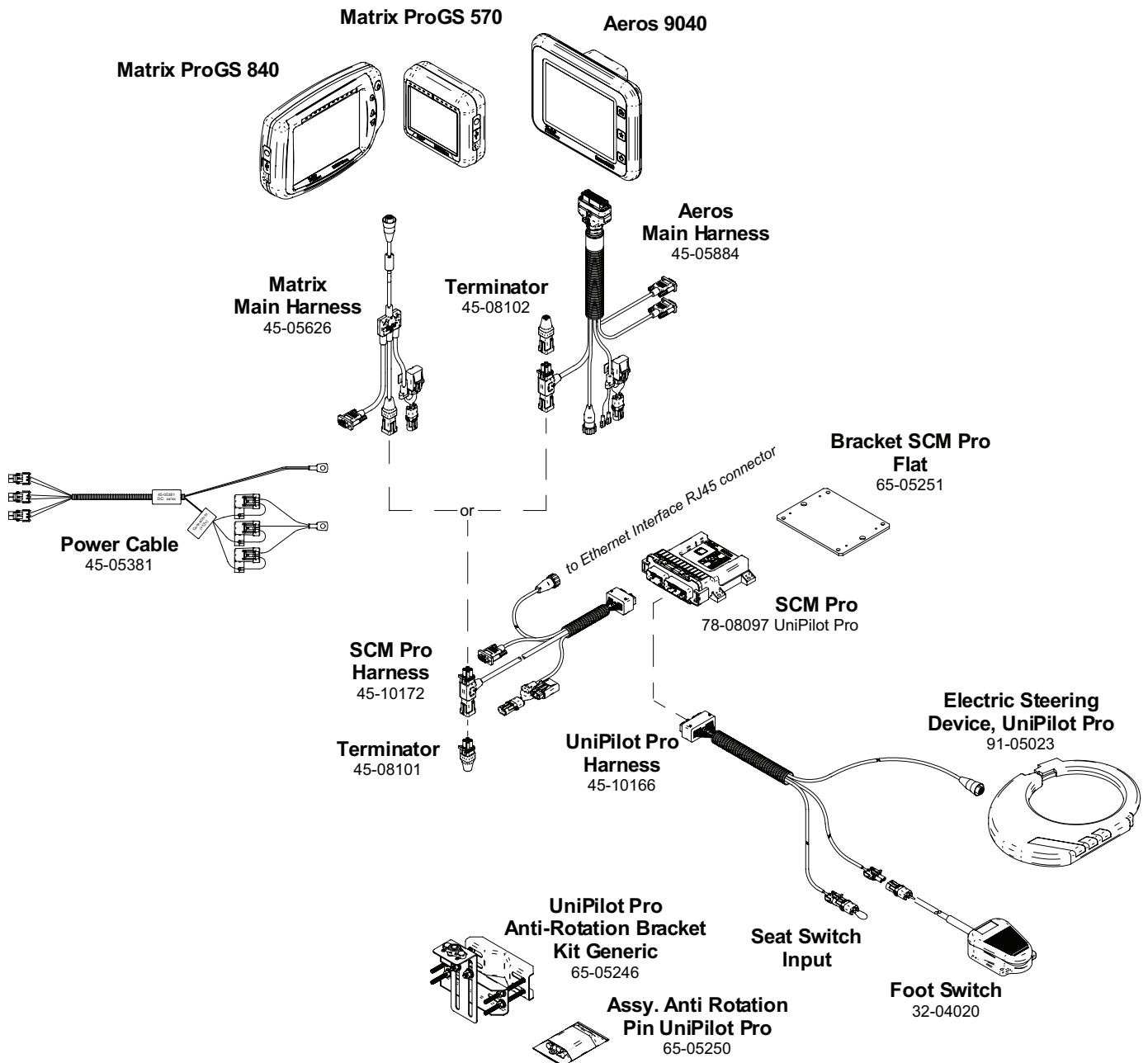

UniPilot Pro Harness Installation Procedure

The UniPilot Pro system cable harness installation steps are described below. Follow them in order, referring to Figure 20 as necessary. This procedure assumes that you have connected your Steering Control Module (SCM Pro) to your Aeros or Matrix Pro GS console. Refer to FieldPilot Pro & UniPilot Pro documentation for further information.

1. Connect the ESD to UniPilot Pro Harness 30 pin connector to the SCM Pro and tighten the connector screw using a 1/4" nut driver. Tighten to 15 to 20 in-lbs (1.7 to 2.2 Nm). Use only the recommended nut driver and do not over tighten.

Figure 21: Connect UniPilot Pro Harness to SCM Pro

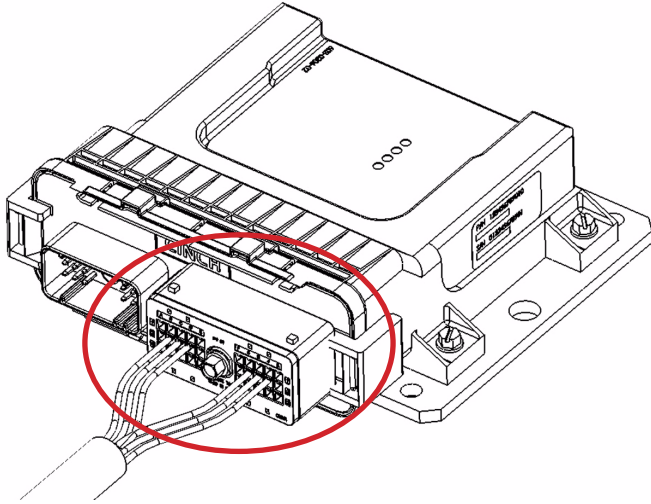

2. Connect the UniPilot Pro Harness to the ESD. Carefully align the circular connector against the mating connector under the ESD and rotate until it fits. Then rotate the external sleeve clockwise to lock the connector. To disassemble, rotate the outer connector sleeve counterclockwise. Never force the connector.

Figure 22: UniPilot Pro Harness to ESD Connection



3. Route the cables in such a way to prevent damage.
4. Installation of the ESD is complete refer to the FieldPilot Pro & UniPilot Pro User Manual for vehicle setup and calibration and operation instructions.

CHAPTER 5 – ON/OFF SWITCH

ESD is equipped with an On/Off switch and LED diagnostic lights. The following sections covers the function of the switch and the lights.

On/Off Switch

The ESD is equipped with an On/Off switch. This allows the operator to disable the ESD unit without powering down the complete UniPilot Pro system. Position the switch to the  to disable the ESD.

Figure 23: On/Off Switch



Led Lights

The ESD has 2 LED lights

- When a steering command is given to the ESD, light 1 will flash Yellow and when the wheel is turning.
- When the ESD is powered, light 2 will be a constant Green.

Figure 24: Led Lights

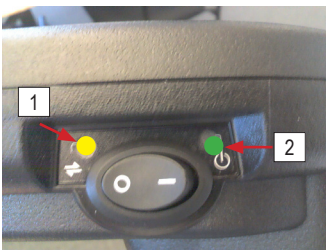

CHAPTER 6 – CARE AND MAINTENANCE

This chapter describes the required care and maintenance for your UniPilot Pro system. Should you require repair services, spare parts or warranty, contact your UniPilot Pro dealer. Only the factory or an authorized service center has the correct parts and training necessary to service your UniPilot Pro system.

- Keep the anti-rotation pin tight at all times. Check the anti-rotation pin every 250 hours of operation or every six months, whichever occurs first, and tighten as necessary to the specified torque. Do not operate the ESD unit if the anti-rotation pin is loose.
- Keep the anti-rotation bracket well secured to the steering column at all times. Check the anti-rotation bracket every 250 hours of operation or every six months, whichever occurs first, and confirm that it is secure and all fasteners are tight. Tighten as necessary.
- Keep the Steering Control Module (SCM Pro) and associated brackets well secured to the vehicle at all times. Verify that the SCM Pro is secure every 250 hours of operation or every six months, whichever occurs first, and tighten as necessary. Do not operate the UniPilot Pro system if the SCM Pro is not well secured. A detached SCM Pro may cause sudden loss of vehicle control while in AutoSteer mode.
- Do not expose your Electric Steering Device (ESD) to water or rain. Store the ESD in a protected location. On open platform tractors, remove it from the vehicle when not in use.
- Check all cables and electrical connectors every six months. Secure any loose cables using cable ties.
- Clean the outside surfaces of your ESD and the three guide rollers using a damp cloth. Do not apply spray cleaners, spray waxes, liquids or lubricants such as WD-40. The use of any liquid cleaning agent or lubricant may damage the internal components of your ESD and will void the factory warranty.
- Always clean the main gear and main gear race with a damp cloth to remove dust before installing the ESD to the steering wheel. This is especially important when moving the ESD between vehicles.
- The ESD is manufactured with sealed bearings and self lubricating components and does not require lubrication. Do not apply oil, grease or spray lubricants.

UNIPILOT[®] PRO

ELECTRIC STEERING DEVICE

Installation Manual



www.teejet.com

A Subsidiary of  *Spraying Systems Co.*[®]

98-05342-EN-A4 R1 English

© TeeJet Technologies 2016