

Peristaltic 500 Injection Pump



Direct Injection Advantages

- The main carrier tank is loaded with clean water, not mixed chemicals.
- Concentrated chemical is accurately injected and mixed just prior to being sprayed out the boom.
- Reduced operator exposure to chemical concentrates
- No pre-mixing of chemicals in the main carrier tank.
- No leftover mixed product at the end of the field to dispose.
- Unused concentrated chemical remains safe and secure in a dedicated holding tank.
- The operator can quickly change from one chemical product to another without cleaning and rinsing the main carrier tank.
- Chemical application rates can be adjusted by varying the concentration of chemical injected into the carrier.

Peristaltic Occlusion Design

Midwest Technologies peristaltic chemical injection pump design utilizes simple technology and incorporates very few moving parts. Peristaltic technology is a precise, wavelike occlusion metering method used to deliver liquid chemical products accurately to the sprayer boom. This technology is widely used in numerous industrial and medical applications. The peristaltic pump design also means that absolutely no moving parts ever make contact with the concentrated chemical.

Patented Chemical Holding Tanks

Midwest Technologies patented chemical holding tanks are made of durable cross-linked polyethylene and incorporate a sloped tank base that empties to molded sump pit. This unique design allows the tank to empty completely, with minimal chemical residue. Other features include a stainless steel mounting base, vented spill proof cap, stainless steel quick coupler and an optional agitation device.

Inject and Mix at the Pump

By injecting concentrated chemical at the main product pump, injection systems based on peristaltic pumps have proven to deliver consistently uniform mixing of chemical and carrier. There is no need to install an additional mixing device in the plumbing system.

Peristaltic Performance

Midwest Technologies single pump peristaltic design uses a five point rotor assembly for precision chemical delivery. Four sizes of pump tubing provide a tremendous range of pumping capacities, with extremely accurate delivery of .5 to 350 oz/min (.015-10.2 l/min). Accuracies of 1% or less can be achieved in the optimum operating range. The built in calibration valve and one-touch electronic calibration button make fine tuning easy.

Reverse Prime

This feature will remove all unused chemical from the delivery line by operating the pump in reverse, depositing all the unused concentrated chemical back into the holding tank.

Contamination and Corrosion Free

In the efficient peristaltic design, only the tube contacts the chemical being delivered. This simple design means there are no mechanical components to become contaminated with chemicals, and no mechanical parts to contaminate the chemical being delivered. Occasional replacement of the tube using quick-connect fittings is the only maintenance requirement. Each tubing replacement effectively gives you a new pump.

Midwest Technologies
2864 Old Rochester Road
Springfield, Illinois 62703 USA
217.753.8424
217.753.8426 fax
www.mid-tech.com

98-01143 R0

www.teejet.com

TeeJet

www.mid-tech.com

MID-TECH

www.lh-agro.com

LH AGRO

Technical Specifications

and Application Information

Peristaltic 500
PUMP/TUBE SELECTION CHART

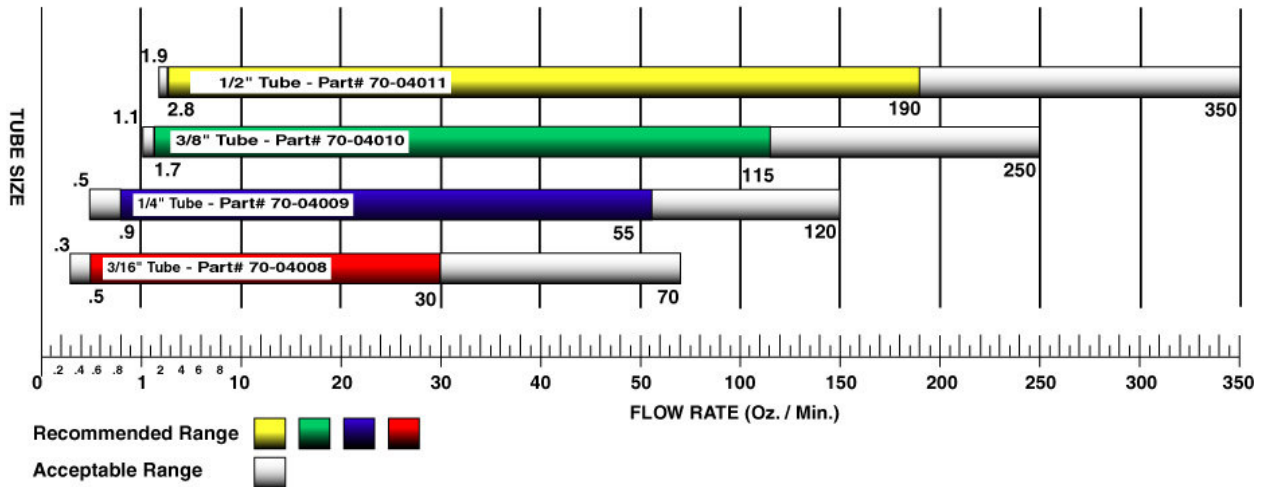

Peristaltic Pump Specifications

Electrical 12 volt DC < 15 Amps @ Max RPM
 Weight..... 34 lbs (15.42 kilos)
 Motor 0-350 RPM @ 12.5vdc
 high torque, high efficiency sealed planetary gear, sealed feedback sensor
 porcelain enamel coated, IP 66 Rated
 Rotor Assy Stainless Steel
 Enclosure..... High Density Polyethylene with integral mounting inserts
 Rotor Cover..... Black Polyethylene
 Operating Temp . 14° F to 140° F (-10° C to 60° C)

Dimensions and Mounting

Dimensions (L 16.5 x W 8.63 x H 17.0)
 Weight..... 34 lbs (15.42 kilos)
 Mounting..... Integral stainless steel threaded inserts (3/8")
 Installation..... Side by Side or Stacked

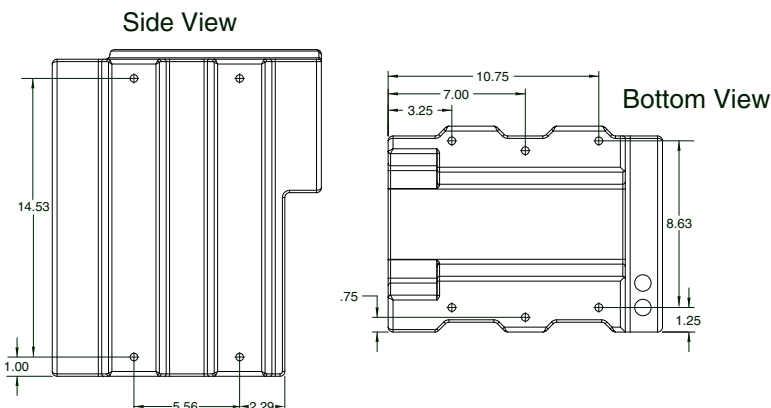
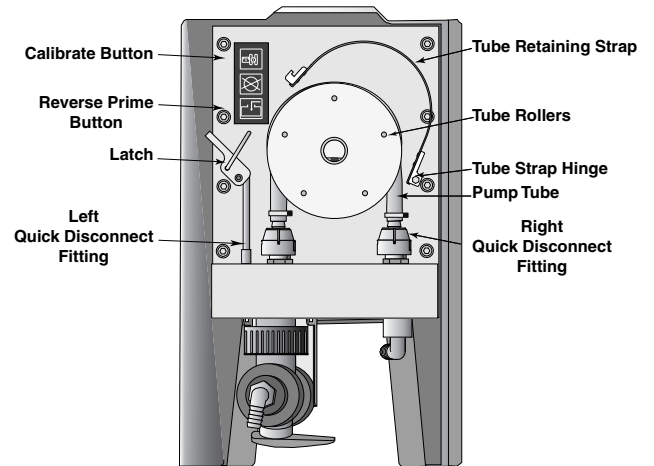

7.5 Gal/28.4 Liter Chemical Tank