

# FIELDPILOT<sup>®</sup>

## USER MANUAL

Assisted Steering Hydraulic Installation Manual for  
Vehicle Kit Number 91-02340

Fits Only AGCO Gleaner R62/R65 (after S/N 66000) and  
R72/R75 (after S/N 76000) Combines



*TeeJet*<sup>®</sup>  
TECHNOLOGIES

A Subsidiary of  Spraying Systems Co.<sup>®</sup>



## FIELDPILOT®

### Copyrights

© 2010 TeeJet Technologies. All rights reserved. No part of this document or the computer programs described in it may be reproduced, copied, photocopied, translated, or reduced in any form or by any means, electronic or machine readable, recording or otherwise, without prior written consent from TeeJet Technologies.

### Trademarks

Unless otherwise noted, all other brand or product names are trademarks or registered trademarks of their respective companies or organizations.

### Limitation of Liability

TEEJET TECHNOLOGIES PROVIDES THIS MATERIAL "AS IS" WITHOUT WARRANTY OF ANY KIND, EITHER EXPRESSED OR IMPLIED. NO COPYRIGHT LIABILITY OR PATENT IS ASSUMED. IN NO EVENT SHALL TEEJET TECHNOLOGIES BE LIABLE FOR ANY LOSS OF BUSINESS, LOSS OF PROFIT, LOSS OF USE OR DATA, INTERRUPTION OF BUSINESS, OR FOR INDIRECT, SPECIAL, INCIDENTAL, OR CONSEQUENTIAL DAMAGES OF ANY KIND, EVEN IF TEEJET TECHNOLOGIES HAS BEEN ADVISED OF SUCH DAMAGES ARISING FROM TEEJET TECHNOLOGIES SOFTWARE.

## PREPARATION

1. Before beginning the installation, thoroughly clean the vehicle to remove dirt and contaminants that might get into the hydraulic circuit.
2. Park the vehicle on a clean, level floor with adequate clearance to work around.
3. Do not attempt to loosen any hydraulic fittings while the engine is running.
4. Allow the motor and the hydraulics to cool until it is no more than warm to the touch before proceeding.
5. Prior to loosening any hydraulic fittings, be sure to have the appropriate plugs and caps available in order to limit loss of hydraulic fluid from the open fittings.



**PREVENT HYDRAULIC SYSTEM CONTAMINATION.** It is essential to thoroughly clean hydraulic system fittings and hose connections prior to disconnecting or removing them. Use a spray cleaner such as “Brake Clean” to prevent hydraulic system contamination. Note that o-rings used on ORB and ORFF type fittings may be damaged by solvent cleaners such as “Brake Clean”. If a fitting is to be cleaned internally, the o-ring should first be removed and cleaned with a fiberless cloth.

### **IMPORTANT!**

**TO AVOID EXCESS LEAKAGE, DO NOT TURN THE STEERING WHEEL WHILE THE FITTINGS ON THE MANUAL STEERING VALVE ARE DISCONNECTED.**



**WARNING: HOT, HIGH PRESSURE FLUID HAZARD.** Hydraulic oil may be hot and under extreme pressure. To prevent serious injury or death, relieve system pressure and allow the system to cool before repairing or disconnecting. Wear proper hand and eye protection when searching for leaks, using wood or cardboard instead of hands. Keep all hydraulic components in good repair.







**WARNING: PINCH POINT HAZARD!** To prevent serious injury or death, avoid unsafe practice while manually operating hydraulic steering circuits. Keep others away and stay clear of mechanical steering linkages.

## KIT CONTENTS

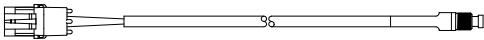
Unpack the installation kit and identify the required parts.

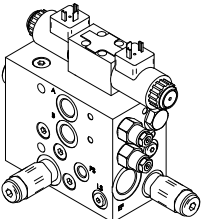
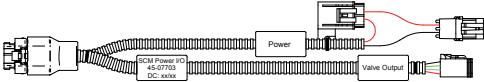
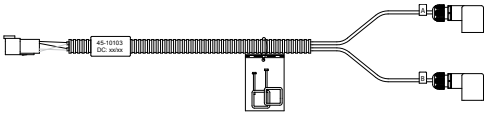
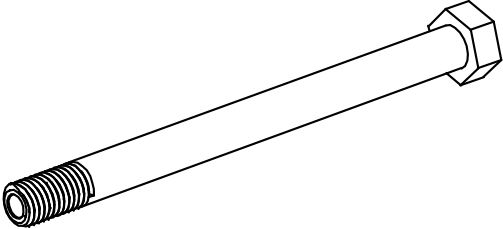
Item	Part Number	Description	Quantity
A	32-04040	Switch, Engage/Disengage.....	1
B	350-0037	Washer, Flat - 3/8" SST .....	4
C	350-0627	Bolt, Hex 3/8-16 x 1", SST .....	2
D	35-02189	Valve, FieldPilot PWM, 3.2GPM, OC .....	1
E	45-07703	Harness, SCM .....	1
F	45-10103	Harness, Valve.....	1
G	60-04089	Bolt, Hex- 3/8-16 x 3-3/4" SST.....	2
H	60-07027	Nut, NyLock 3/8-16, SST .....	4
I	65-05153	Bracket, Hyd. Mount .....	1
J	68-01135	Hose, Hyd. - 1/2" x 35", #8FJIC x #8FJIC 90° .....	1
K	68-01155	Hose, Hyd. - 3/8" x 66", #6FJIC x #6FJIC 90° .....	2
L	68-01156	Hose, Hyd. - 5/8" x 64", #10FJIC x #10FJIC 90° .....	2
M	68-02009	Adapter, Hyd. Run Tee - #8 JIC .....	1
N	68-02022	Adapter, Hyd. Run Tee - #6 JIC .....	2
O	68-02046	Adapter, Hyd. - #10MJIC x #12MORB .....	2
P	68-02078	Adapter, Hyd. 90° - #6MJIC x #6FJIC.....	2
Q	68-02082	Adapter, Hyd. - #6MJIC x #8MORB.....	2
R	68-02093	Adapter, Hyd. 90° - #8MJIC x #8FJIC.....	1
S	68-02094	Adapter, Hyd. - #8MJIC x #8MORB.....	1
T	90-50013	Cable Tie Kit, 15 .....	1
U	91-07011	Steering Wheel Switch Kit .....	1
V	98-05131	Installation Manual FP, Gleaner R62/R65/R72/R75.....	1

Item	Part #	Description	Illustration
A	32-04040	Switch, Engage/Disengage, Momentary	
B	350-0037	Washer, Flat - 3/8" SST	
C	350-0627	Bolt, Hex 3/8-16 x 1", SST	
D	35-02189	Valve, FieldPilot PWM, 3.2GPM, OC	
E	45-07703	Harness, SCM	
F	45-10103	Harness, Valve	
G	60-04089	Bolt, Hex- 3/8-16 x 3-3/4" SST	
H	60-07027	Nut, NyLock 3/8-16, SST	

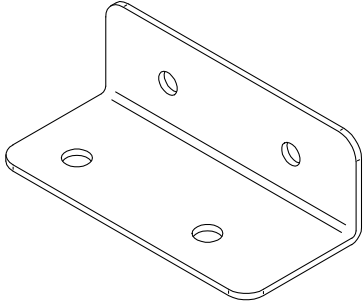
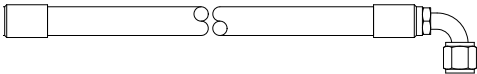
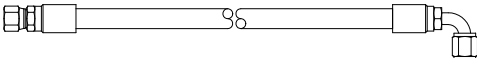
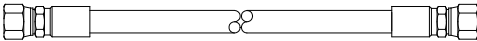
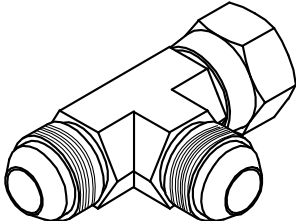
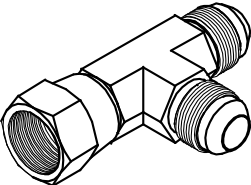
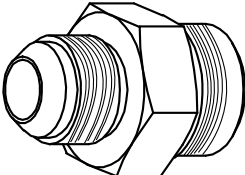
Item	Part #	Description	Illustration
I	65-05153	Bracket, Hyd. Mount	
J	68-01135	Hose, Hyd. - 1/2" x 35", #8FJIC x #8FJIC 90°	
K	68-01155	Hose, Hyd. - 3/8" x 66", #6FJIC x #6FJIC 90°	
L	68-01156	Hose, Hyd. - 5/8" x 64", #10FJIC x #10FJIC 90°	
M	68-02009	Adapter, Hyd. Run Tee - #8 JIC	
N	68-02022	Adapter, Hyd. Run Tee - #6 JIC	
O	68-02046	Adapter, Hyd. - #10MJIC x #12MORB	

Item	Part #	Description	Illustration
P	68-02078	Adapter, Hyd. 90° - #6MJIC x #6FJIC	
Q	68-02082	Adapter, Hyd. - #6MJIC x #8MORB	
R	68-02093	Adapter, Hyd. 90° - #8MJIC x #8FJIC	
S	68-02094	Adapter, Hyd. - #8MJIC x #8MORB	
T	90-50013	Cable Tie Kit, 15	
U	91-07011	Steering Wheel Switch Kit	
V	98-05131	Installation Manual FP, Gleaner R62/R65/R72/R75	

Figure 1-1: Hydraulic Diagram



Existing Hoses —————

Hoses From Kit —————

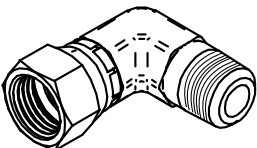
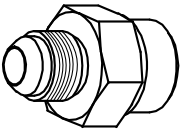
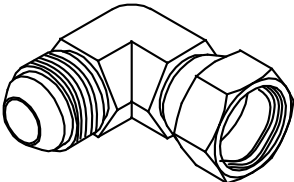
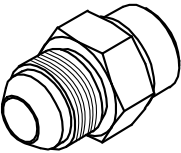
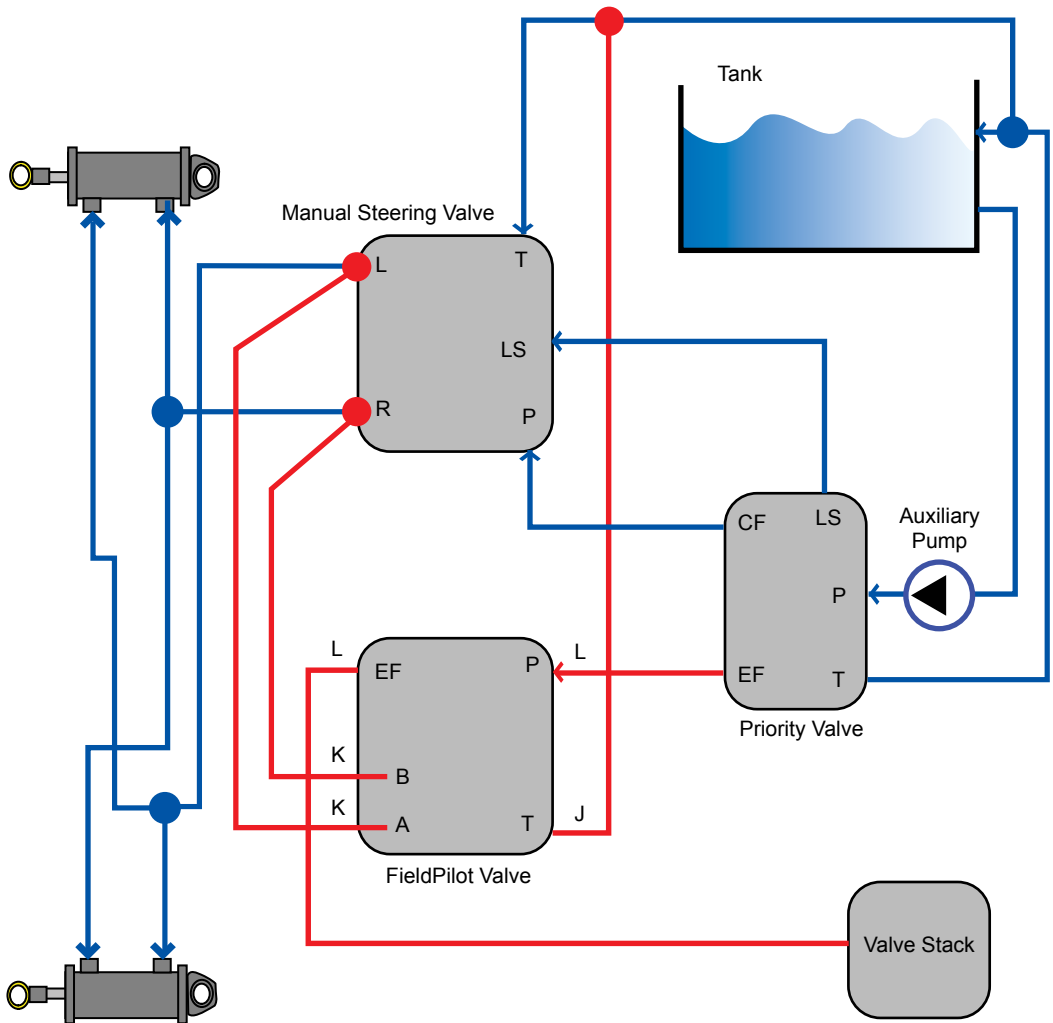
## INSTALLATION



If there are questions concerning the installation of the FieldPilot system on this vehicle, or due to the changes in component specifications the parts supplied in the kit are not exactly as presented in this document, please contact your dealer or TeeJet Customer service representative for clarification before installation. TeeJet Technologies is not responsible for misuse or incorrect installation of the system.

**NOTE: BE VERY CAREFUL TO ABSOLUTELY SECURE ALL CABLES AND HOSES SO THAT THEY DON'T INTERFERE WITH THE MANY MOVING PARTS OF THE MACHINE!**

## Overview of the Machine

- The valve will mount on the right side of the machine.
- The P, EF, & T connections will be on the right side of the machine.
- The Left & Right steer connections will be at the orbital under the cab.

**NOTE: All references to left and right are stated as if the user is seated in the driver's seat.**

Figure 1-2: Overview of the Machine

---

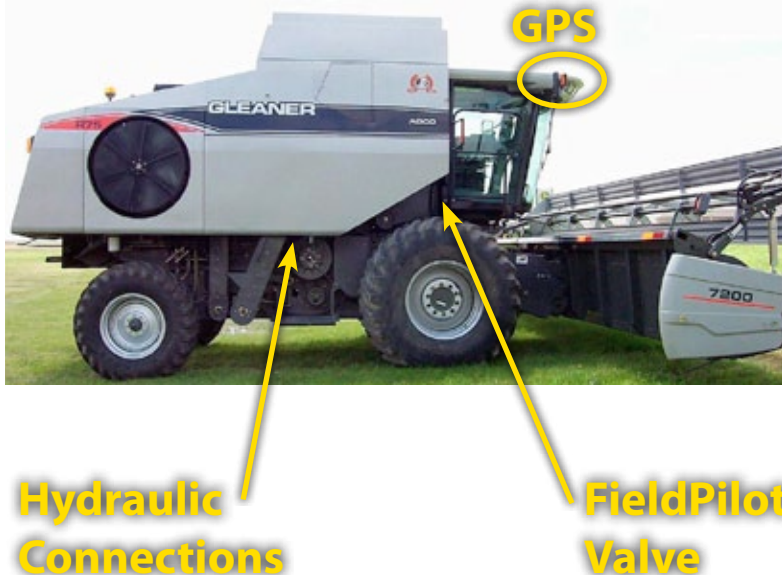

## 1. PREPARE THE FIELDPILOT VALVE

Install adapters (O) in the P and EF ports. Install adapters (Q) in the A and B ports, then install adapter (S) in the T port. Next attach adapters (P) to adapters (Q) in the A & B ports. Finally attach adapter (R) to adapter (S) in the T port.

Figure 1-3: Prepare the FieldPilot Valve

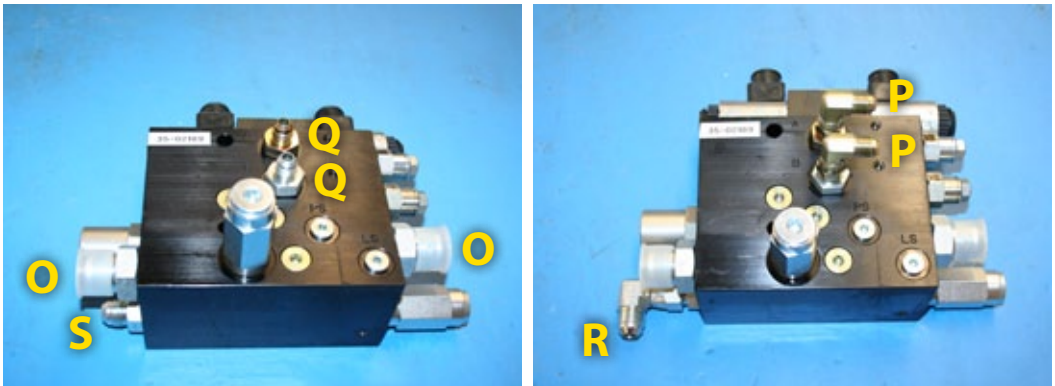

## 2. MOUNT THE FIELDPILOT VALVE

The FieldPilot valve will be mounted on the outside of the right side frame rail that runs forward underneath the cab. Depending on the machine model, there may already be one hole in the frame, in which case this hole will be the rear-most hole used to mount valve bracket (I).

Figure 1-4: Identify Mounting Hole

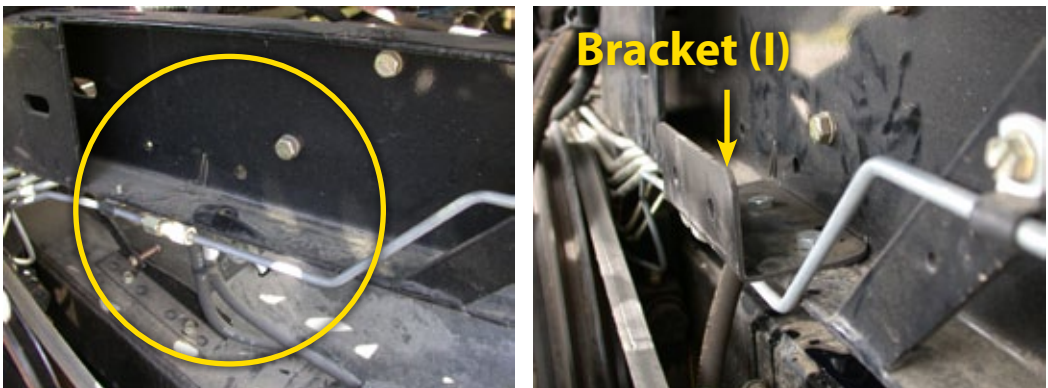

Be careful to identify which face on valve bracket **(I)** mounts to FieldPilot valve **(D)**. Using the other face of the bracket as a template, mark and then drill the required 7/16" hole(s) in the frame and secure the bracket to the frame using hardware **(B, G & H)**.

Using hardware **(B, G & H)**, mount the FieldPilot valve **(D)** to the valve bracket **(I)** making sure that the solenoid valve coils face toward the rear of the machine.

*Figure 1-5: Mount FieldPilot Valve*

---

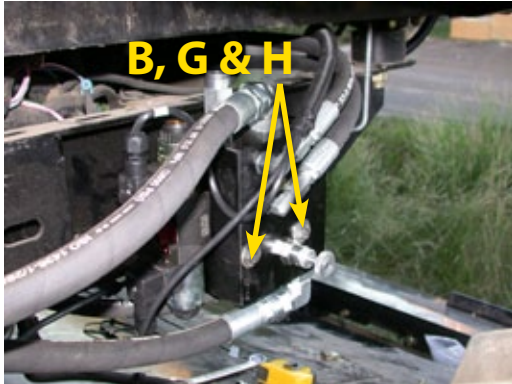

### 3. DISCARD EXISTING EXCESS FLOW HOSE

Locate the existing hose that runs from the Excess Flow (EF) port of the Priority Valve to the hydraulic valve stack and remove it. USE PLASTIC CAPS TO PREVENT EXCESS LEAKAGE FROM THE OPEN PORTS.

*Figure 1-6: Discard Existing Excess Flow Hose*

---

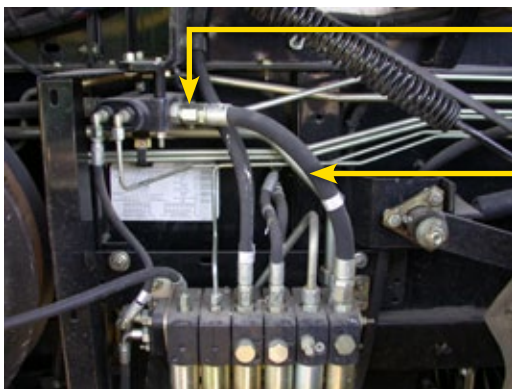

**Priority valve  
Excess Flow port**

**Remove and discard  
existing hose**

#### 4. INSTALL EXCESS FLOW HOSE

Connect hose (L) to adapter (O) installed in the EF port on the FieldPilot Valve. Connect the other end of this hose to the -10JIC adapter on the hydraulic valve stack left open when the original excess flow hose was discarded. Take care routing the hose to be sure it is clear of all drive belts and cannot rub on other components.

*Figure 1-7: Install Excess Flow Hose*

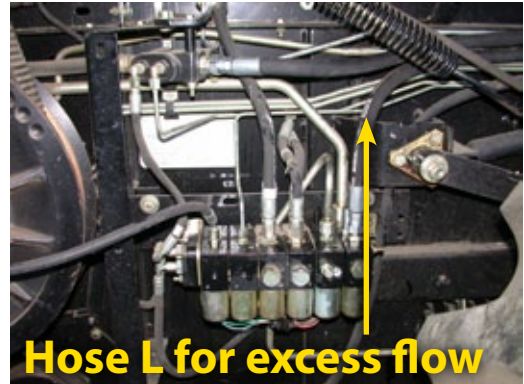

#### 5. INSTALL PRESSURE HOSE

Connect hose (L) to adapter (O) installed in the P port of the FieldPilot valve. Connect the end of the hose to the EF port of the Priority valve left open when the original excess flow hose was discarded.

*Figure 1-8: Install Pressure Hose*

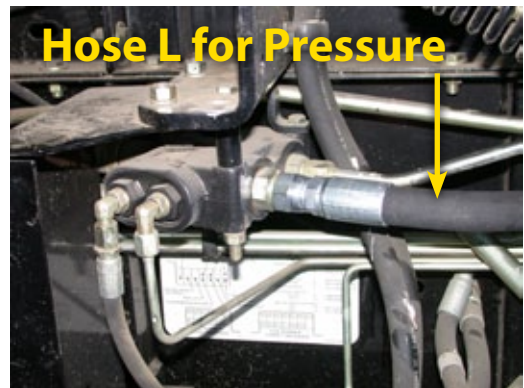

## 6. INSTALL TANK HOSE

Locate the Tank oil connection under the cab and above the feeder housing. If there is an unused (capped) connection point, connect hose **(J)** to this connection point or use optional run tee adapter **(M)** to create an additional connection point. Connect hose **(J)**.

*NOTE: The machine may not be exactly as illustrated due to the absence/presence of a number of machine options.*

Connect the other end of hose **(J)** to adapter **(R)** installed in the T port of the FieldPilot valve. USE PLASTIC CAPS TO PREVENT EXCESS LEAKAGE FROM THE OPEN PORTS.

Figure 1-9: Install Tank Hose

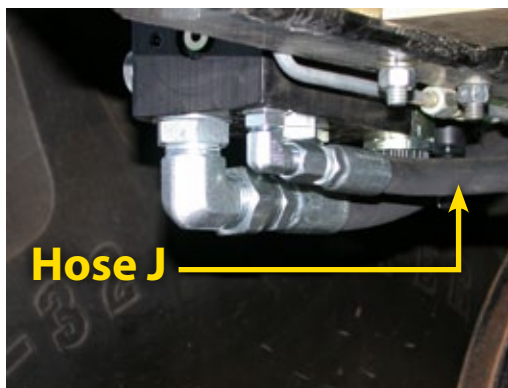
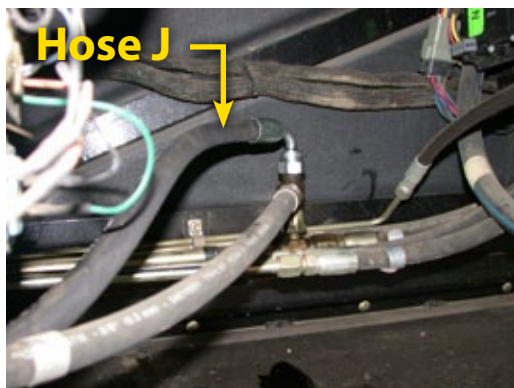

## 7. INSTALL LEFT AND RIGHT STEER HOSES

Locate the left and right steer hoses where they connect to the right side of the orbital valve (ports closest to the 1/4" Load Sense hose). Taking care to remember the port that each of the original hoses was connected to, remove the hose. Install run tee **(N)** to the adapter on the orbital and connect the original hose to the run on the new run tee. Connect the 90° end of hose **(K)** to the branch of the run tee. Connect the other end of hose **(K)** to adapter **(P)** installed in the A and B ports of the FieldPilot valve. Repeat this process for the second run tee and hose. Do not be concerned about which hose **(K)** goes to which port on the orbital or FieldPilot valve.

Figure 1-10: Install Left and Right Steer Hoses

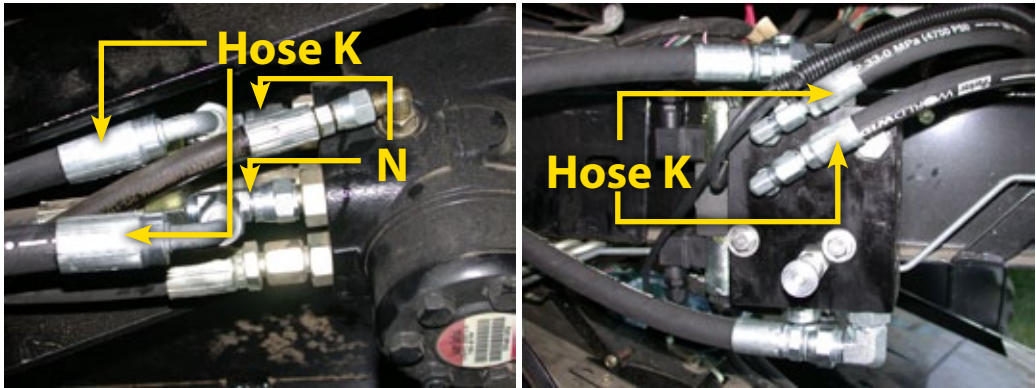

## 8. SECURE HOSES

Be sure all hoses are routed in a manner that prevents them from rubbing on other parts of the machine. Use the heavy tie-straps provided to secure the hose away from moving parts.

## 9. INSTALL THE VALVE CONTROL CABLE

Connect the FieldPilot valve control cable (**F**) to the solenoids on the FieldPilot valve and route the cable into the cab to connect to the SCM harness. Do not be concerned at this time about which connector is connected to which solenoid coil.

Figure 1-11: Install Valve Control Cable

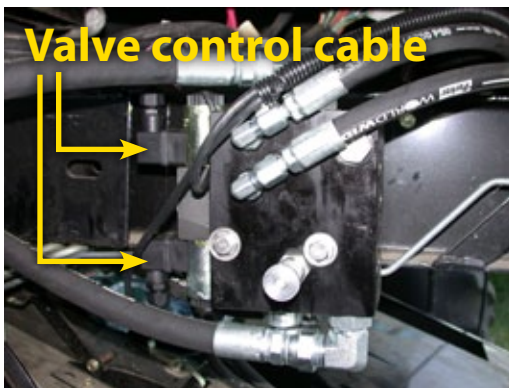

## 10. INSTALLATION OF ENGAGE/DISENGAGE SWITCH

Connect item **(A)** to the connector on the SCM harness labeled Remote Engage/Disengage. Install the push button in a location that is easily accessible during operation of the machine. This switch **(A)** is not required if the optional foot switch 32-04020 is used.

*Figure 1-12: Engage/Disengage Switch*

---



## 11. INSTALL STEERING DISENGAGE SWITCH (KIT 91-07011)

Remove the left side steering column cover below the steering wheel. Cut the provided self-adhesive magnets in half so they fit better, and stick at least two of these magnets to the shaft immediately above the universal joint. Bend the aluminum mounting bracket as illustrated, and mount the disengage sensor on the backside of the steering column as shown (hose clamp not included).

Set the clearance between the sensor and magnets to 1/8" and rotate the steering wheel in both directions to be sure that the sensor does not contact the magnets or the shaft. Connect the sensor to the Steering Control Module Cable labeled 'Steering Wheel Sense' and secure the cables in position so that they cannot interfere with the rotation of the steering shaft, or the full range of the fore/aft and extended/retracted positions of the adjustable steering column. It may be necessary to remove the convoluted tubing from the sensor cable in order to route the cable nicely inside the steering column cover.

*Note: These illustrations are for the R75 model. Other models may vary.*

Figure 1-13: Install Steering Disengage Switch (Kit 91-07011)

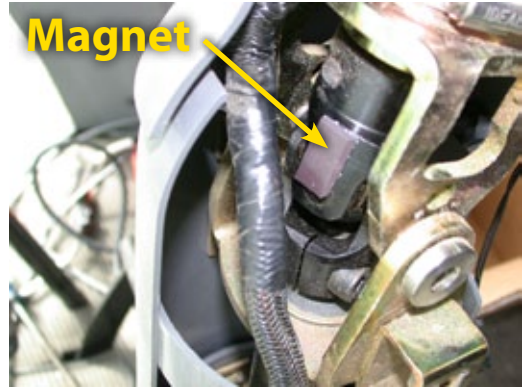

## 12. RECOMMENDED ELECTRONICS INSTALLATION

The SCM should be mounted as far forward in the cab as possible. The control console can be mounted to the operator's preference. The GPS antenna should be mounted as far forward as possible on top of the cab on a metal surface of at least 4" square.

Figure 1-14: Recommended Electronics Installation



## 13. VERIFY OPERATION OF HYDRAULICS AND SET THE STEERING CONTROL RATE

Clean and pick up the area around the vehicle and make certain that it is safe to operate. Start the engine and check hydraulic connections for leaks. Rotate the steering wheel from one extreme to the other and back to center, check for leaks. While steering through the extremes of movement, check the cables and hoses for wear points and strain, adjust as necessary.

*PLEASE NOTE THE FOLLOWING RECOMMENDATION FROM AGCO:*

After servicing of the steering cylinders and/or hydraulic hoses, any air that may be trapped in the hydraulic system must be bled in order to provide smooth, instantaneous operation of the steering system. To bleed the steering cylinders and/or hydraulic hoses, proceed as follows:

Jack up the rear axle (on both sides) until the rear wheels are off the ground. Securely block the rear axle. Start the engine and turn the steering wheel as if making a right hand turn (as far as it will go) until the left hand steering cylinder is completely retracted and the right hand steering cylinder is completely extended. Turn the steering wheel as if making a left hand turn (as far as it will go) until the left hand steering cylinder is completely extended and the right hand steering cylinder is completely retracted. Repeat these steps until the steering cylinders operate smoothly and instantaneously in both directions.

**The final oil flow rate adjustment is accomplished through the Matrix console. The target lock to lock time is 8 seconds and the valve frequency is 110. Refer to the Matrix manual for further instructions.**

*NOTE: To activate the manual overrides, a tool such as a small screwdriver or allen wrench must be inserted into the end of the coil to depress the override button.*



**WARNING: PINCH POINT HAZARD!** To prevent serious injury or death, avoid unsafe practice while manually operating hydraulic steering circuits. Keep others away and stay clear of mechanical steering linkages.

## 14. COMPLETE ELECTRONIC INSTALLATION

Refer to the owner's manual supplied with the automated steering system to complete the electronic installation and setup.

# FIELDPILOT®

## USER MANUAL

---

A series of equipment-specific hydraulic installation kits have been developed to work in conjunction with your assisted steering system. This kit contains the necessary components and instructions to install assisted steering hydraulics on the AGCO Gleaner R62/R65 (after S/N 66000) and R72/R75 (after S/N 76000) Combines. Please review this manual thoroughly before beginning the installation process.



1801 Business Park Drive  
Springfield, Illinois 62703 USA  
Tel: (217) 747-0235 • Fax: (217) 753-8426  
[www.teejet.com](http://www.teejet.com)

A Subsidiary of  *Spraying Systems Co.*®

98-05131 R2  
© TeeJet Technologies 2010