

DYNAJET[®] FLEX

INSTALLATION, SETUP AND USER GUIDE

Software Version 1.02
with Optional High Flow Option

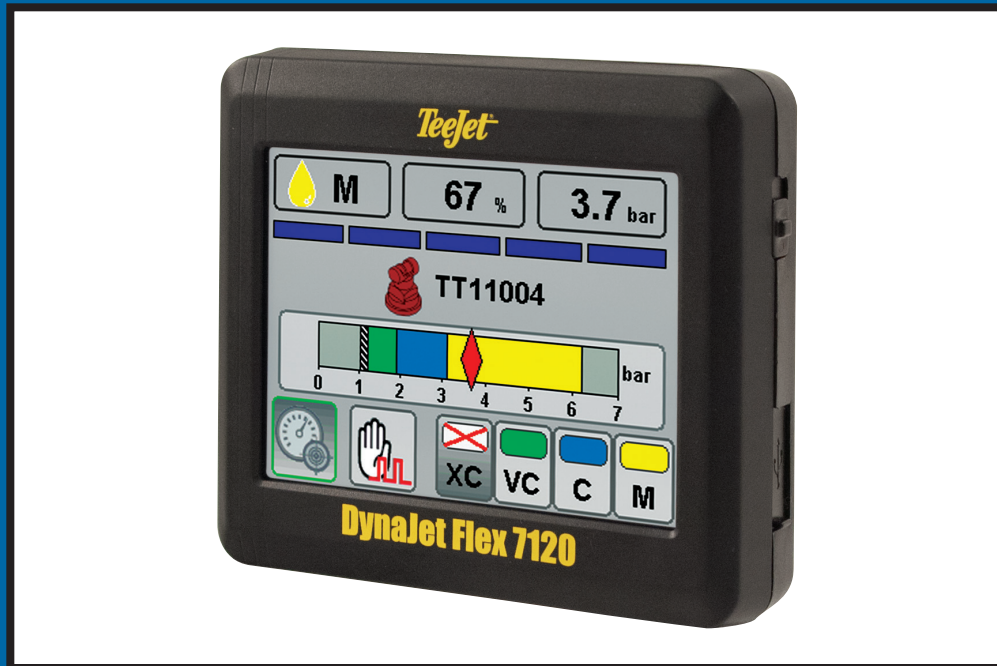

TeeJet[®]
TECHNOLOGIES

A Subsidiary of  Spraying Systems Co.[®]

Copyrights

© 2016 TeeJet Technologies. All rights reserved. No part of this document or the computer programs described in it may be reproduced, copied, photocopied, translated, or reduced in any form or by any means, electronic or machine readable, recording or otherwise, without prior written consent from TeeJet Technologies.

Trademarks

Unless otherwise noted, all other brand or product names are trademarks or registered trademarks of their respective companies or organizations.

Limitation of Liability

TEEJET TECHNOLOGIES PROVIDES THIS MATERIAL "AS IS" WITHOUT WARRANTY OF ANY KIND, EITHER EXPRESSED OR IMPLIED. NO COPYRIGHT LIABILITY OR PATENT IS ASSUMED. IN NO EVENT SHALL TEEJET TECHNOLOGIES BE LIABLE FOR ANY LOSS OF BUSINESS, LOSS OF PROFIT, LOSS OF USE OR DATA, INTERRUPTION OF BUSINESS, OR FOR INDIRECT, SPECIAL, INCIDENTAL, OR CONSEQUENTIAL DAMAGES OF ANY KIND, EVEN IF TEEJET TECHNOLOGIES HAS BEEN ADVISED OF SUCH DAMAGES ARISING FROM TEEJET TECHNOLOGIES SOFTWARE.

Table of Contents

DYNAJET® FLEX OVERVIEW	1
INSTALLATION	1
CONSOLE	1
INSTALLATION – STANDARD MODE	3
DynaJet® Drivers	3
Power	3
Tip Harnesses	3
Pressure Sensor Interface Kit.....	4
Boom Interface Module (BIM).....	4
DynaJet® Interface.....	4
CAN Cables & Terminators.....	4
INSTALLATION – HIGH FLOW MODE	5
DynaJet® Interface and Drivers.....	5
Connect Terminators	5
Tip Harnesses	5
Connect CAN Cables to Drivers	5
Driver Battery Cables.....	5
Boom Harnesses.....	5
Pressure Sensor	5
DynaJet® 7120 Console	5
Other Battery Cable	5
INITIAL STARTUP	8
Favorites.....	8
Setup	8
Units.....	9
Number of Sections	9
Maximum Pressure Sensor Value	9
Tip Selection	9
<i>Select Tip Series</i>	9
<i>Select Tip Capacity</i>	9
Ready to Pressure Test the System	10
Work Screen.....	10
On Screen Indicators.....	10
<i>Droplet Size Chart</i>	10
USER SETTINGS	11
OEM Settings.....	13
Enable/Disable Options	13
TUNING DYNAJET®	13
DYNAJET® TIP SELECTION	14
Tip Selection Example.....	15
55295 E-CHEMSAVER® MAINTENANCE INSTRUCTIONS	16
General Disassembly and Reassembly.....	16
APPLICATION RATES AT GIVEN SPEED	17

DYNAJET® FLEX OVERVIEW

The DynaJet Flex controller works in conjunction with an existing rate controller that regulates flow via a control valve or pump regulation to achieve a target application rate while maintaining target droplet size(s) when a speed change occurs. This system only works with automatic rate controllers that use flow based monitoring systems and not pressure based monitoring systems. Automatic rate controllers equipped for both flow and pressure based control should have the pressure-based system disabled to work in conjunction with DynaJet Flex.

The independent automatic rate controller loop performs the same as it would if the DynaJet controller were not present. The DynaJet Flex controller changes flow output to each individual tip based upon input provided from the operator about the optimum droplet size (pressure) for the application.

INSTALLATION

CONSOLE

The DynaJet Flex console is designed to provide years of service under typical agricultural and turf operating conditions. A tight fitting enclosure means that typical dusty environments will not cause operational problems. While occasional splashing of water will not damage the unit, the DynaJet Flex console is not designed for direct exposure to rain. Take care not to operate the DynaJet Flex console in wet conditions.

Figure 1: DynaJet Flex 7120 Console Front and Back

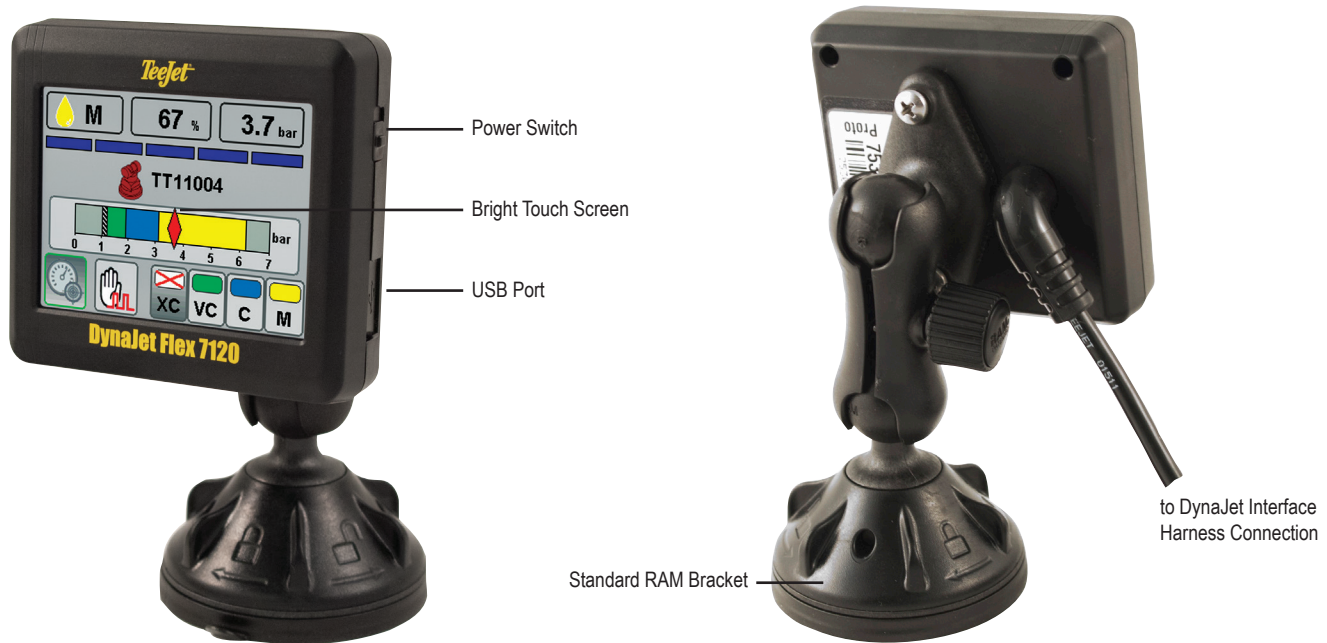

Safety Information

TeeJet Technologies is not responsible for damage or physical harm caused by failure to adhere to the following safety requirements.

As the operator of the vehicle, you are responsible for its safe operation.

The DynaJet Flex is not designed to replace the vehicle's operator.

Be sure that the area around the vehicle is clear of people and obstacles before and during engagement.

The DynaJet Flex is designed to support and improve efficiency while working in the field. The driver has full responsibility for the quality and work related results.

Figure 2: System Diagram - Standard Mode

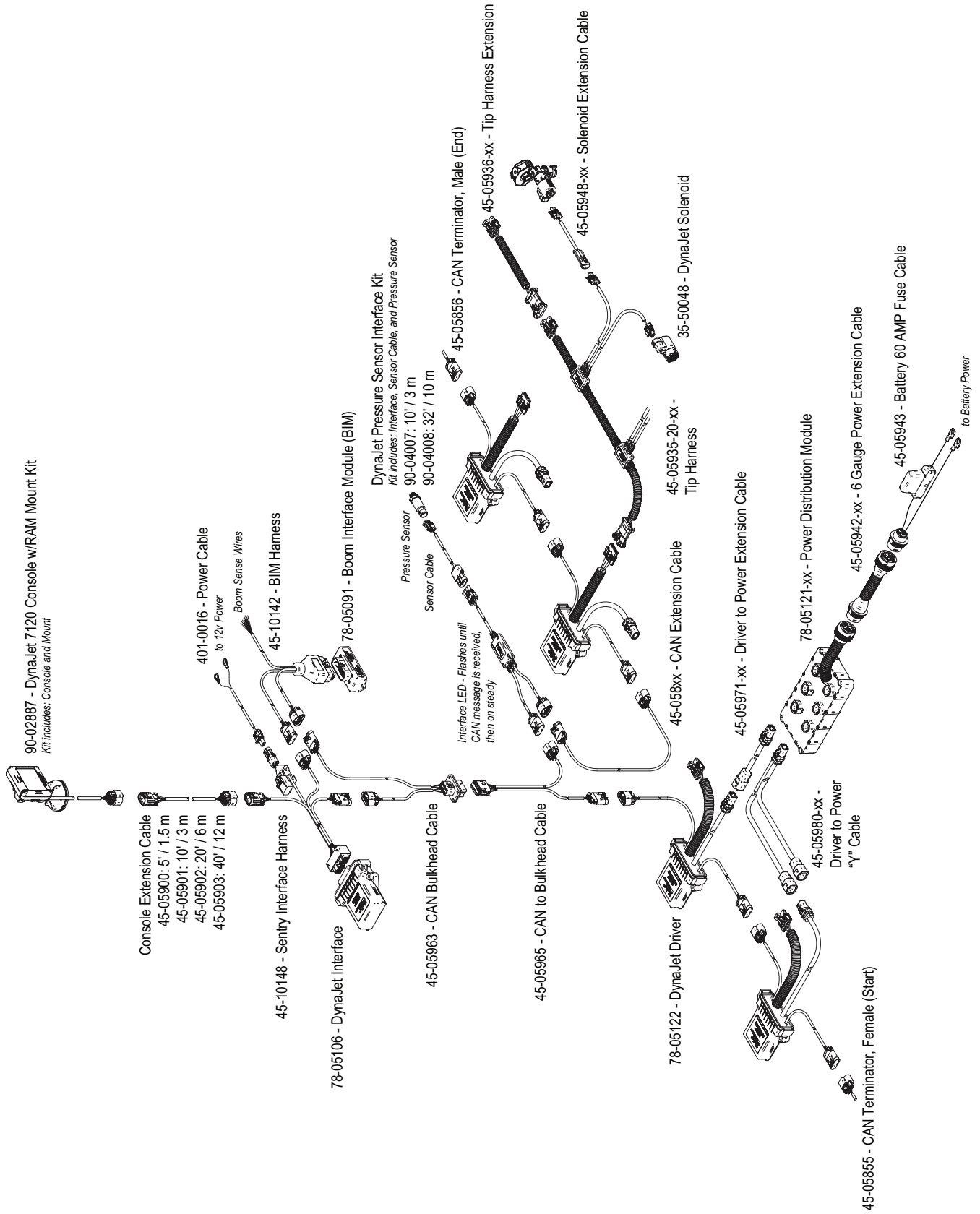

INSTALLATION – STANDARD MODE

DynaJet® Drivers

There will be one DynaJet Driver 78-05122 per boom section with a limit of 20 tips per section.

- Mount them so they are at the end of each section that is closest to the middle of the boom.

Power

Power will be sourced from the battery using the 60 amp fused cable 45-05943.

Power from the battery will be routed to the boom using the 6 gauge power cables 45-05942-xx

The Power Distribution Modules 78-05121-xx will connect to the 45-05942-xx cables.

Power will then route from 78-05121-xx to each DynaJet Driver 78-05122 using cables 45-05971-xx.

Figure 3: Installation Diagram - Standard Mode

Tip Harnesses

When installing Tip Harnesses 45-05935-xx-xx always start with Section 1 and continue to the last section.

Each section will require Tip Harnesses designed for your specific tip spacing and number of tips.

- Tip harnesses are built with an even number of outputs.
- Some sections will use more than one harness to equal the number of tips in that section.

The yellow and white solenoid cables on the tip harnesses must alternate across the entire boom. When sections have odd numbers of tips then accounting for the altering can be accomplished one of two ways:

- a. By crossing the two solenoid cables
- b. By installing Tip Harness Reversing Adapters 45-05952

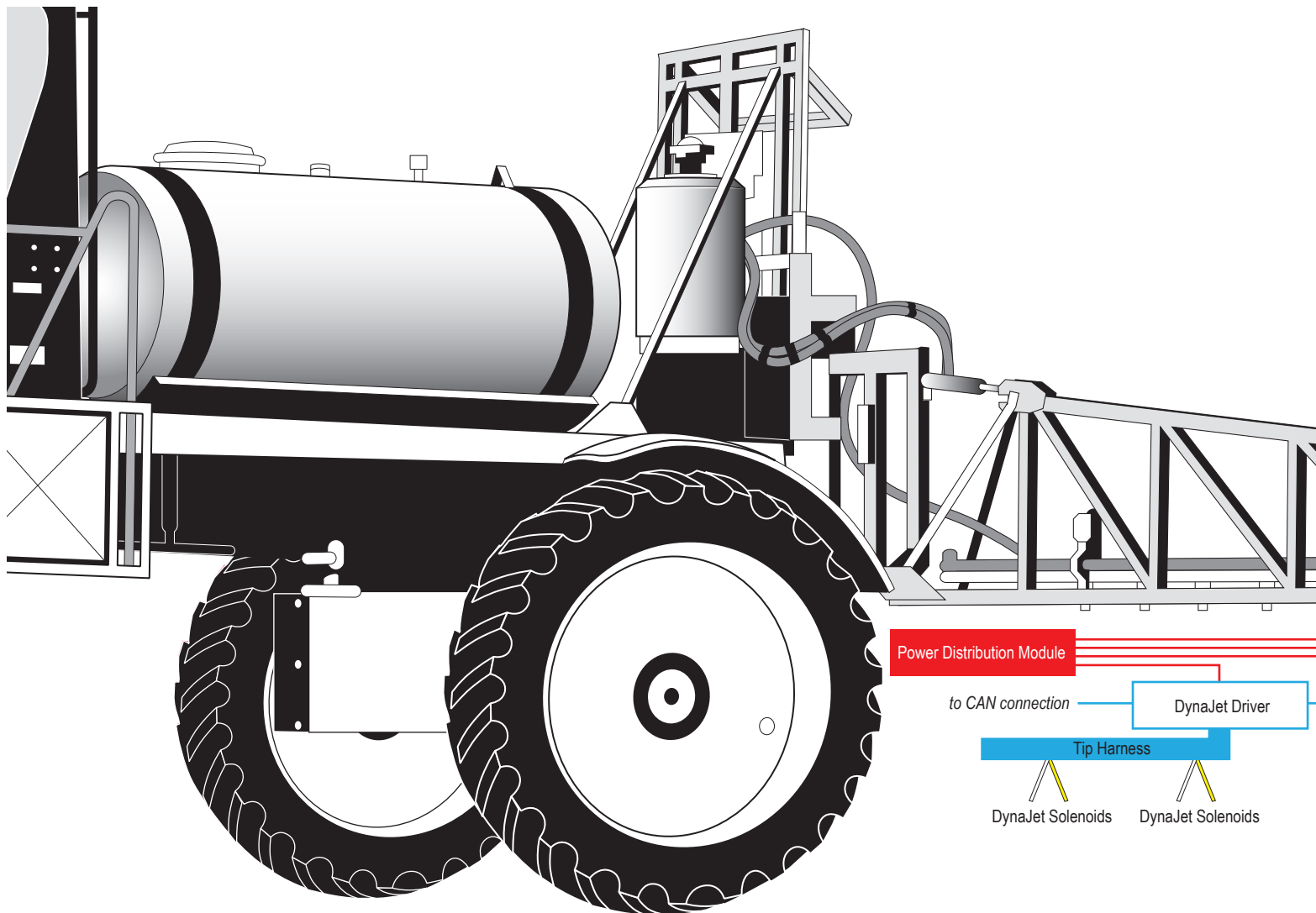

Pressure Sensor Interface Kit

The DynaJet system requires Pressure Sensor Interface Kit 90-04007 or 98-04008 to be installed.

- The Pressure Sensor Interface Kit should be mounted close to the boom manifold.

Boom Interface Module (BIM)

The Boom Interface Module (BIM) 78-05091 is used by the DynaJet System for boom sense.

The BIM Harness connects between the BIM and the CAN.

On the BIM Harness 45-10142, the Boom Sense Wires (or flying leads) are supplied to tie into existing machine boom section 12V ON/OV OFF outputs.

If not using 45-10142, some machine specific harnesses are available.

The BIM can be mounted in the cab or outside depending upon your installation.

DynaJet® Interface

The DynaJet Interface 78-05106 connects to the Sentry Interface Harness 45-10148:

The Sentry Interface Harness connects to

- The Console 75-30119 (extension cable may be used)
- Power 12V for powering the CAN
- CAN

The DynaJet Interface can be mounted in the cab or outside depending upon your installation.

CAN Cables & Terminators

The Start Terminator 45-05855 must be connected to the DynaJet Driver 78-05122 for Section 1.

CAN cables must be connected in series:

- To each DynaJet Driver 78-05122
- To the Boom Interface Module 78-05091 (via BIM Harness 45-10142)
- To the DynaJet Interface 78-05106 (via Sentry Interface Harness 45-10148)
- To the Pressure Sensor Interface Kit (via Pressure Interface 78-05110)

The End Terminator 45-05856 must be connected to the Driver Module 78-05122 for the last section.

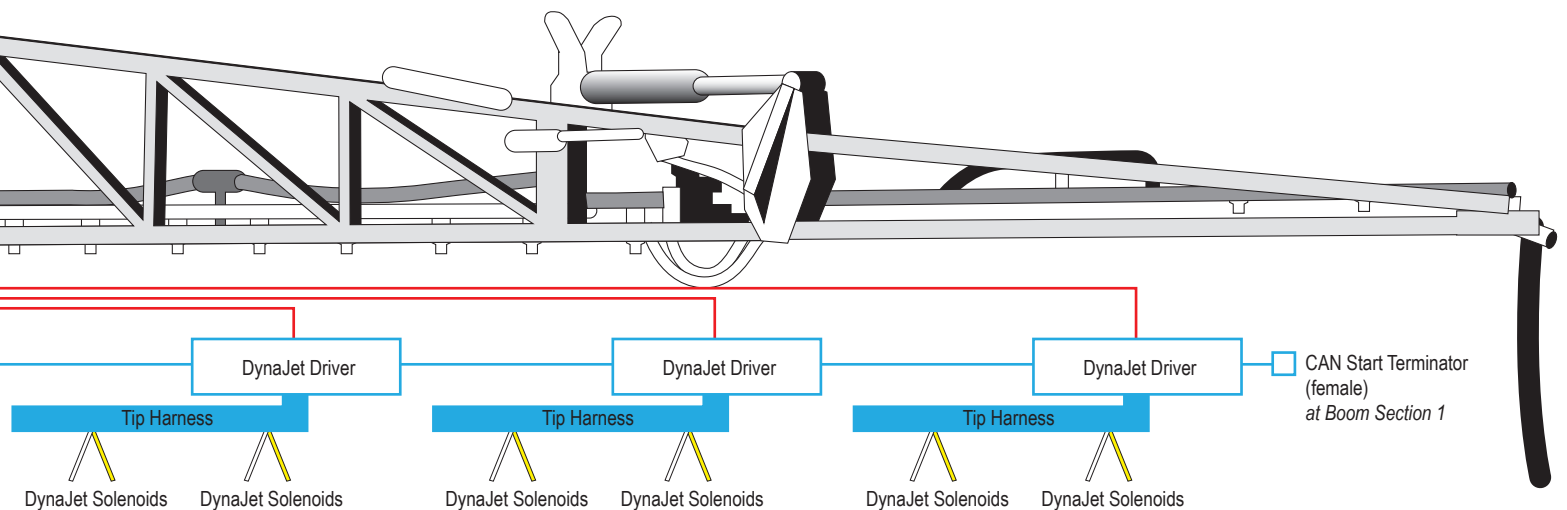

INSTALLATION – HIGH FLOW MODE



The following illustration and steps are only a guideline of an installation based on a specific vehicle configuration. Installations on other vehicles may vary. If there are questions concerning the installation of the DynaJet Flex system on this vehicle, or due to the changes in component specifications the parts supplied in the kit are not exactly as presented in this document, please contact your dealer or TeeJet Customer service representative for clarification before installation. TeeJet Technologies is not responsible for misuse or incorrect installation of the system.

DynaJet® Interface and Drivers

Step 1a – Mount the **(F)** DynaJet HF Drivers 78-05124 onto brackets, one for each boom section.

Step 1b – Mount the **(D)** DynaJet HF Interface 78-05123, connecting to the **(C)** DynaJet Interface Harness 45-10177, and **(H)** Boom Harness 45-10178.

Connect Terminators

Step 2a – Connect the **(I)** Start Terminator 45-05855 to **(K)** 4 Tip Harness (1-4) 45-10174, first section.

Step 2b – Connect the **(J)** End Terminator 45-05856 to **(M)** 4 Tip Harness (9-12) 45-10176, last section.

Tip Harnesses

Step 3 – Install Tip Harness **(K)** 4 Tip Harness (1-4) 45-10174, **(L)** 4 Tip Harness (5-8) 45-10175, and **(M)** 4 Tip Harness (9-12) 45-10176. Each harness features two solenoid connections per tip body, supporting (4) tip bodies in total.

NOTE: Specific section breakdown may vary by installation

Connect CAN Cables to Drivers

Step 4 – Using the **(E)** CAN extension cables, connect the **(I)** DynaJet HF Drivers 45-05124 to the **(D)** DynaJet HF Interface 78-05123.

Driver Battery Cables

Step 5 – Connect the battery cable 45-05987 to the three **(3)** **(F)** DynaJet HF Drivers 78-05124, and to the battery.

Boom Harnesses

Step 6 – Install the **(H)** Boom Harnesses 45-10178, 45-10179, or 45-10181 connecting to the **(D)** DynaJet HF Interface 78-05123.

Pressure Sensor

Step 7 – Connect the Boom Pressure Sensor 0-10 bar to the **(C)** DynaJet HF Interface Harness 45-10177. The Pressure Sensor Interface Kit should be mounted close to the boom manifold

DynaJet® 7120 Console



Step 8 – Connect the **(A)** DynaJet 7120 Console 90-02887 to the **(C)** DynaJet HF Interface Harness 45-10177 via Console extension cables.

Other Battery Cable

Step 9 – Connect 401-0012 to the battery and route leads as needed.

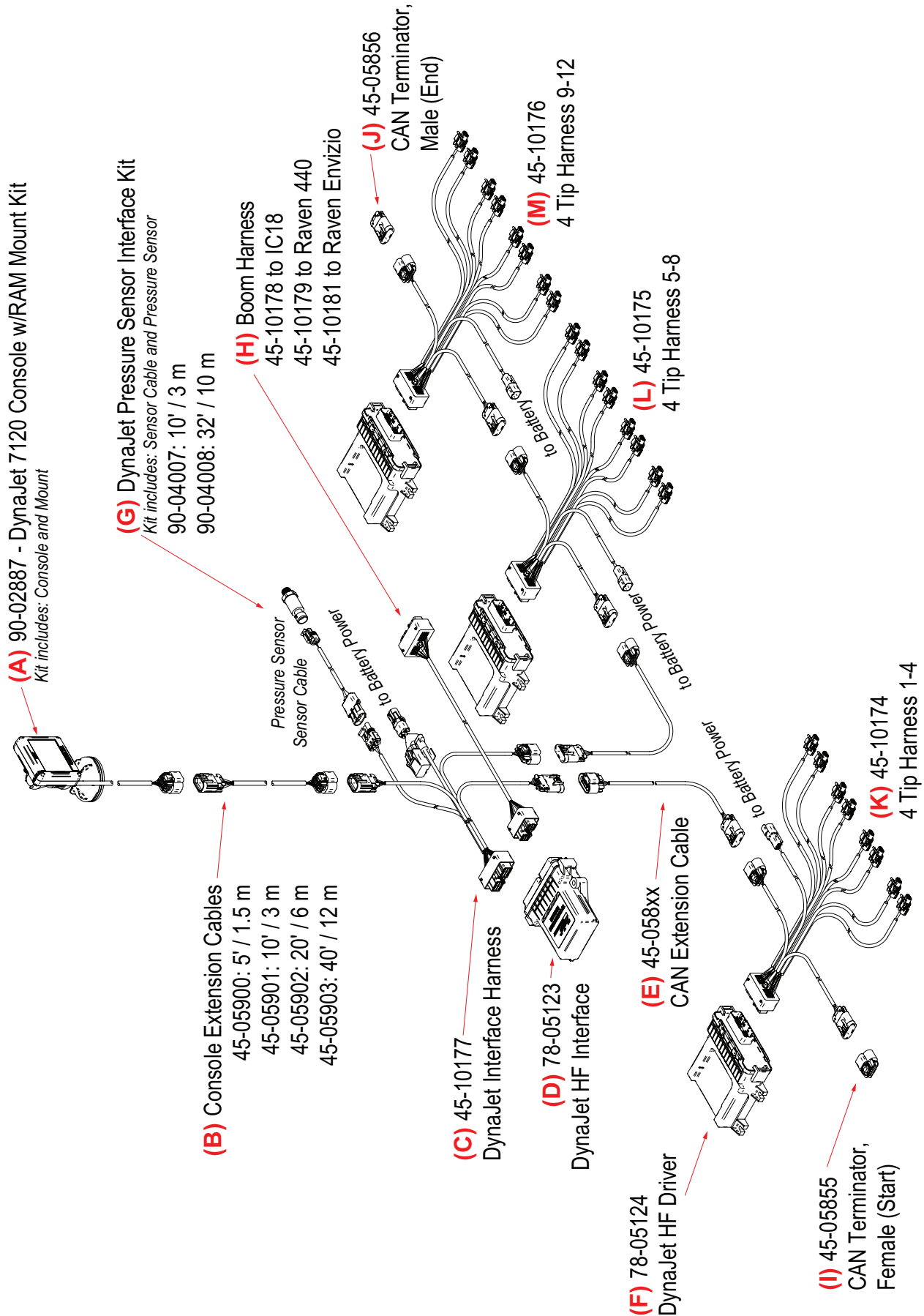
Figure 4: System Diagram - High Flow Mode

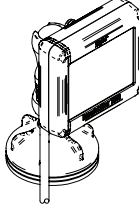
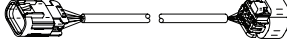
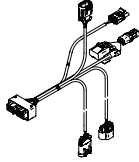
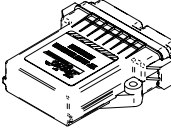
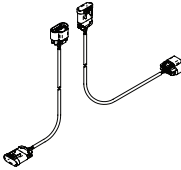
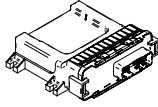
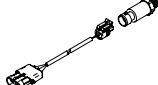

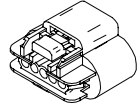
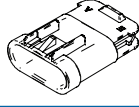
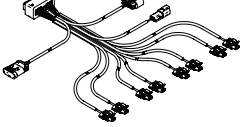
Item	Part #	Description	Illustration
A	90-02887	DynaJet 7120 Console	
B	45-05900: 5' / 1.5 m 45-05901: 10' / 3 m 45-05902: 20' / 6 m 45-05903: 40' / 12 m	Console Extension Cable	
C	45-10177	DynaJet Interface Harness	
D	78-05123	DynaJet HF Interface	
E	45-05857: 3' / 1 m 45-05858: 6' / 2 m 45-05859: 12' / 4 m 45-05864: 35' / 10.5 m	CAN Extension Cable	
F	78-05124	DynaJet HF Driver	
G	90-04007: 10' / 3 m 90-04008: 32' / 10 m	DynaJet Pressure Sensor Interface Kit	
H	45-10178 to IC18 45-10179 to Raven 440 45-10181 to Raven Envizio	Boom Harness	
I	45-05855	CAN Terminator, Female (Start)	
J	45-05856	CAN Terminator, Male (End)	
K	45-10174	4 Tip Harness 1-4	
L	45-10175	4 Tip Harness 5-8	
M	45-10176	4 Tip Harness 9-12	

INITIAL STARTUP

This section will explain basic setup of the values required for first-time setup of a DynaJet Flex system.

When these settings are completed, initial operation and fine-tuning should be possible.

To access setup menu from the work screen, touch center of the screen.

- Select from:
 - ▶ Favorites – The FAVORITE icon ★ represents favorite spray tips. This function automatically stores the most recent five (5) tips chosen. Use this to quickly access your most frequently used spray tips.
 - ▶ Setup – The SETUP icon ⚡ is used to access settings. This will enter the configuration menu.
 - ▶ Tip Selection – The SPRAY TIP icon 🍷 is used to select the spray tip style and capacity. Once chosen here, the spray tip style and capacity is automatically added to the favorites list.
- Press HOME icon 🏠 to return to the main work screen.

Figure 5: Options Menu

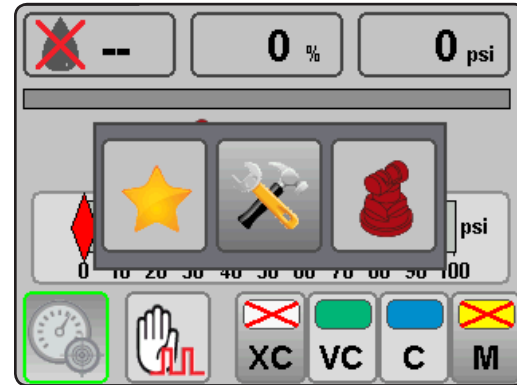

Favorites

★ The favorite icon represents favorite spray tips. This function automatically stores the most recent five (5) tips chosen. Use this to quickly access your most frequently used spray tips.

Figure 6: Favorites

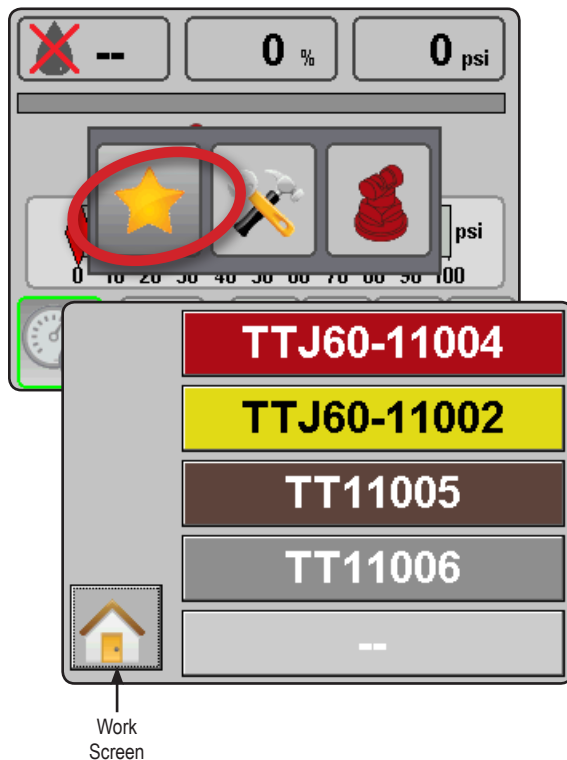

Setup

⚡ The setup icon is used to access settings. This will enter the configuration menu. Selections are automatically saved when adjusted.

NOTE: Not all settings are listed below. See “User Settings” section of this guide for additional settings and details.

Figure 7: Setup

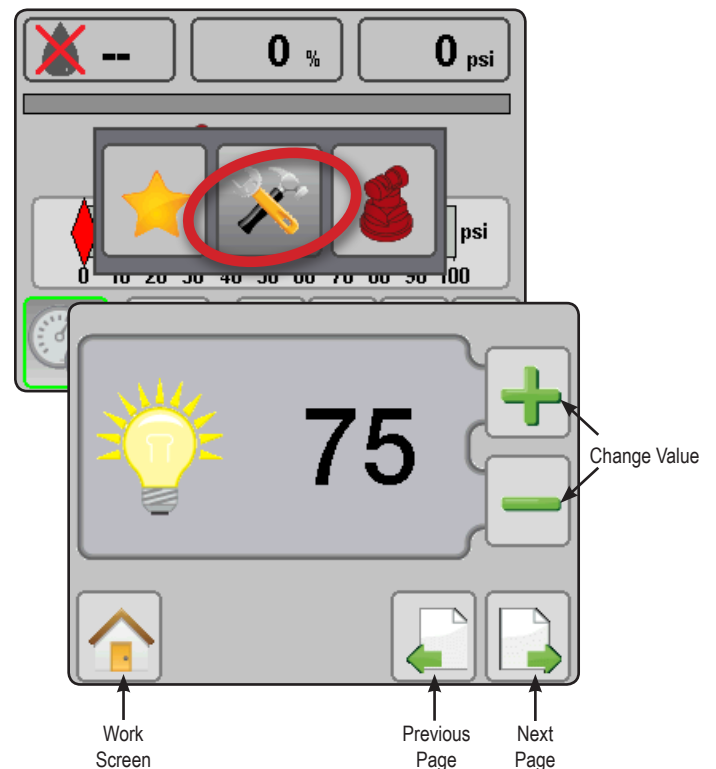

Units

Sets the units to US (psi) or Metric (bar)

Figure 8: Units



Number of Sections

Set the number of boom sections. This should match the number of sections used on the spray controller. Range is 1 to 15.

Figure 9: Number of Sections



Maximum Pressure Sensor Value

Verify this value by looking at the pressure sensor description. Values will be either 10 bar (145 psi) or 25 bar (363 psi).

If pressure value displayed on the DynaJet Flex console are not accurate compared to a mechanical gauge, adjust this value until there is a match.

- ▶ Increasing the value will reduce the pressure value displayed during operation
- ▶ Decreasing this value will increase the pressure value displayed during operation

Figure 10: Max Pressure Sensor Value

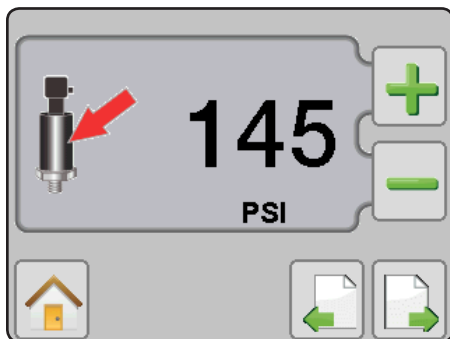

Tip Selection

 Accesses the tip selection process to select which tip is to be used. At this time only TeeJet tips are supported.

Figure 11: Tip Selection



Select Tip Series

Use the green up and down arrows to highlight the correct spray tip series/family.

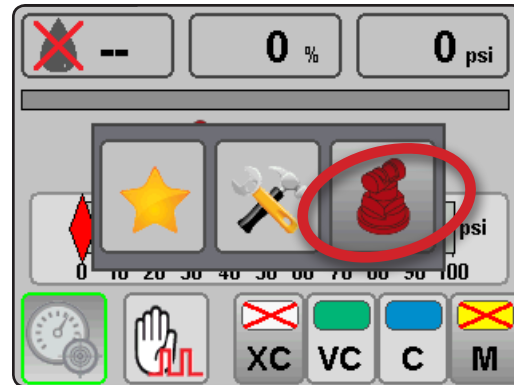
Figure 12: Select Tip Series



Select Tip Capacity

With the correct tip capacity highlighted, select the HOME icon  to return to operating mode. The selected tip will be active and will automatically be added to the favorites list.

Figure 13: Select Tip Capacity



Ready to Pressure Test the System

1. Ensure that current rate control system is operating at the optimum level. Set DynaJet operating mode to manual and set PWM duty cycle at 100%. This will make the system operate as if DynaJet was not present. Use this configuration to verify the rate control system is operating normally.
2. Keep DynaJet operating mode on manual and change PWM duty cycle to 50%. Use this configuration to verify the rate control system is operating normally.
3. Confirm boom section functionality by observing the row of rectangles below the on the operating display.
4. Switch the master switch ON (on rate control or other boom section control switches) and individual sections one at a time. Make sure each section appropriately changes color to blue. With the master switch OFF, all active sections will be gray again.
5. Start pump and ensure no leaks.
6. Verify pressure on mechanical gauge matches the digital pressure display within reason. If not, adjust max pressure sensor value as previously described.
7. Configure in PWM mode DynaJet at duty cycle of 50%. Confirm each e-ChemSaver (ECS) is pulsating.

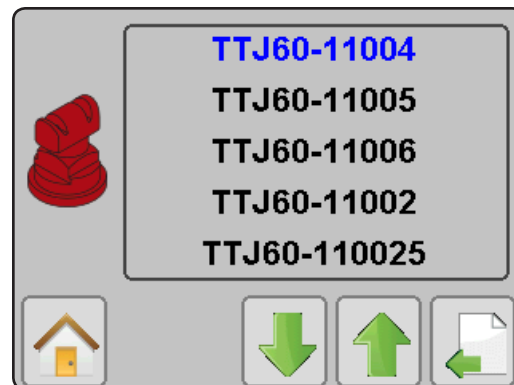
At this point the system is functioning. Further details for fine-tuning the system are available in the User Settings section of this guide.

Work Screen

On Screen Indicators

Current Droplet Size – Displays the current droplet size using both the appropriate color droplet icon and size letter code.

PWM Duty Cycle – Displays the current PWM duty cycle as a percentage.

Active Solenoid (High Flow Mode only) – Displays if one or both sets of solenoid are active.

Actual Pressure – Displays the actual pressure.

Current Tip Selection – Displays the current selected tip.

Boom Status

- ▶ Blue – turned on (Standard Mode or High Flow Mode single solenoid active)
- ▶ Green – turned on (High Flow Mode both solenoids active)
- ▶ Empty – turned off

Pressure Gauge

- ▶ Red Diamond – Actual pressure
- ▶ Colors – Droplet size,

Operation Modes

- ▶ Tip Mode (Pressure) – When the user changes the desired drop sizes choices (via the droplet size selectors checkboxes) the system will recalculate the desired pressure. It will then adjust the PWM duty cycle to attempt to attain the desired pressure in the system.
- ▶ Manual Mode (PWM) – The user can manually adjust the PWM duty cycle to attempt to attain the desired pressure in the system.

Droplet Size Selectors

- ▶ Red X and grayed out – Not selected

High Flow Mode

- ▶ Single – one set of solenoids active
- ▶ Dual – both sets of solenoids active

Droplet Size Chart

When choosing a spray tip that produces droplet sizes in one of the eight droplet size classification categories, it is important to remember that a single tip can produce different droplet size classifications at different pressures. A tip might produce medium droplets at low pressures, while producing fine droplets as pressure is increased.

Category	Symbol	Color code
Extremely fine	XF	Violet
Very fine	VF	Red
Fine	F	Orange
Medium	M	Yellow
Coarse	C	Blue
Very coarse	VC	Green
Extremely coarse	XC	White
Ultra coarse	UC	Black

Figure 14: Work Screen - Standard Mode

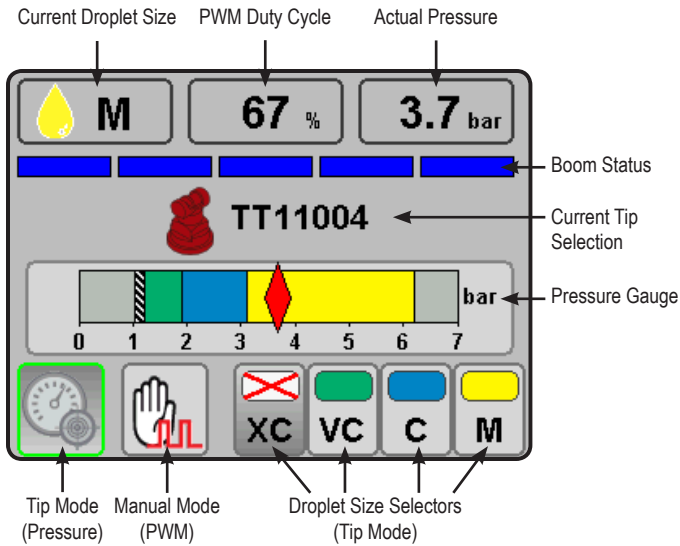

Figure 15: Work Screen - High Flow Mode Single

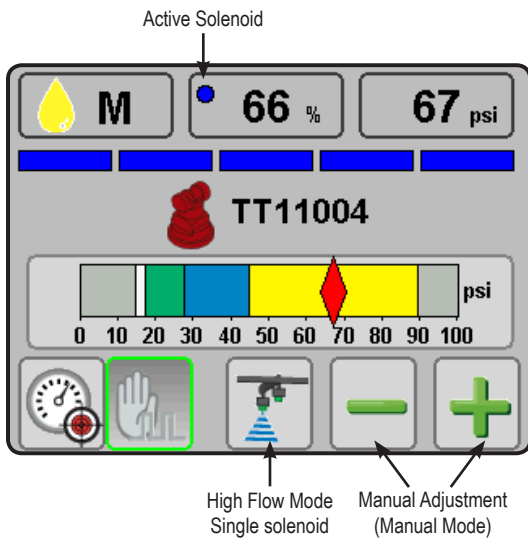
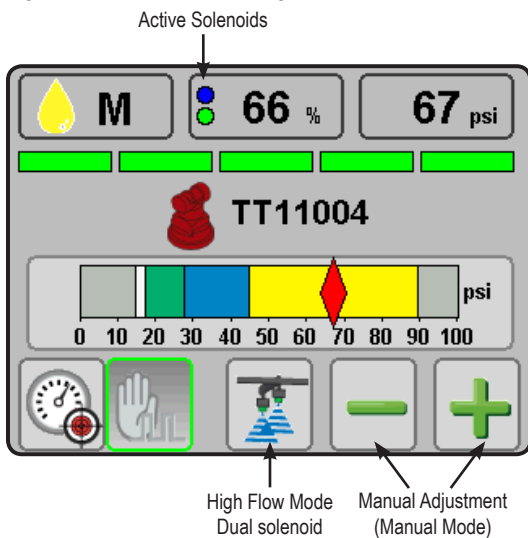

Figure 16: Work Screen - High Flow Mode Dual



USER SETTINGS

If there are questions concerning the setup of the DynaJet Flex, please contact your dealer or TeeJet Customer service representative for clarification before operation. TeeJet Technologies is not responsible for misuse or incorrect operation of the system.

Setup is used to configure Units, Display Brightness, Key Beep, Number of Sections, Boom Section On/Off Beep, Maximum Pressure Sensor Value, Minimum Duty Cycle, Control Hold Delay, Fine Gain, Coarse Gain, and Coarse Gain On/Off.

Display Brightness

Sets the brightness level of the display. Range is 5% to 100% in 5% increments.

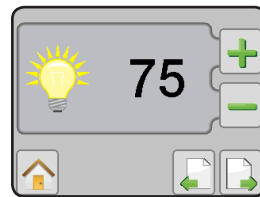

Units

Sets the units to US (psi) or Metric (bar).



Key Beep

Enable/disable all beeping from console.

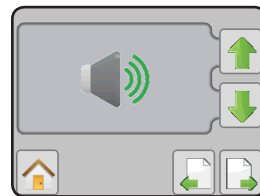

Number of Sections

Set the number of boom sections. Range is 1 to 15.



Number of Tips (High Flow Mode Only)

Set the number of tip locations for each boom section.
Range is 1 to 120.

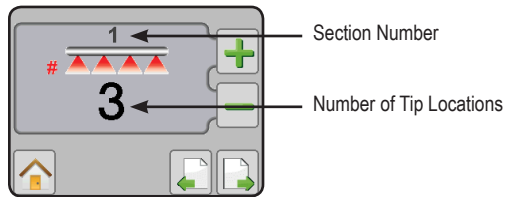

Boom Section On/Off Beep

Enable/disable beep when a boom section is turned on or off.

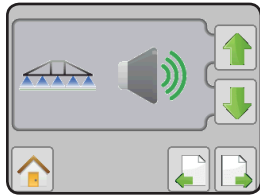

Maximum Pressure Sensor

Sets the value from the pressure sensor description. Either 10 bar (145 psi) or 25 bar (363 psi).

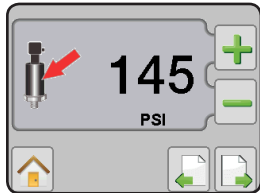

Minimum Duty Cycle

Sets the minimum duty cycle to which the DynaJet will control. Default is 30%, minimum is 20%.

Higher values reduce the overall control range of the system.

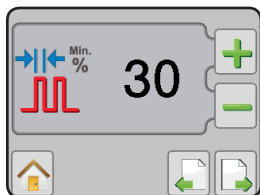

Control Hold Delay

When any boom switch changes state, DynaJet Flex will not make control adjustments for the specified time period. Range is 0.0 to 10.0 seconds. Default is 1.0 second.



Fine Gain

Allows the control system to make minor adjustments when close to the target, with the goal of stable pressures and minimal overshoot of target. Range is 0 to 100. Default is 30.

Fine gain settings are 1/10 as powerful gain as coarse gain settings.

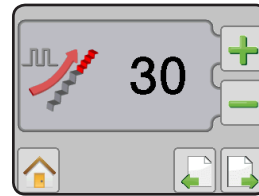

Coarse Gain

This is the more aggressive gain setting and will have the largest impact on the stability and function of the DynaJet Flex system. Coarse gain makes major adjustments to duty cycle to attempt to bring actual pressure back to the target. A Coarse Gain setting that is too high will result in pressure oscillation. Range is 1 to 100. Default is 5.



Coarse Gain On

This setting determines the threshold at which Coarse Gain becomes active. Value is shown in the pressure units previously chosen (bar or PSI). Range is 0.07 to 1.38 bar (1 to 20 psi).

For example, if operating in PSI units with a setting of 7; coarse gain becomes active when actual pressure is 7 or more PSI away from the target value. Increasing this value makes the Coarse setting in effect less of the time (higher value means higher tolerance between actual pressure and target pressure). Decreasing this value means coarse regulation is active more frequently. Setting coarse gain ON too high would disable the feature. Decreasing this value too much will result in pressure oscillations.

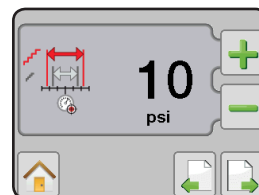

Coarse Gain Off

This setting determines the threshold at which Coarse Regulation is switched OFF and Fine Regulation takes over. Value is shown in the pressure units previously chosen (bar or PSI). Range is 0.07 to 1.38 bar (1 to 20 PSI).

This value must be lower than Coarse Gain ON. For example, if operating in PSI units and with a setting of 4; Coarse Regulation will be switched OFF (and Fine Gain becomes active) when the difference between Target and Actual Pressure is 4 psi or less. Regulation will remain in Fine until the error reaches the Coarse Gain ON value described above.

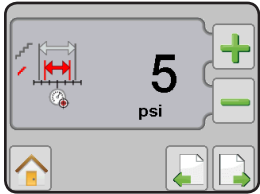

OEM Settings

The settings described below are engineering and development values used in development of the DynaJet Flex system. Do not alter these settings unless directed by TeeJet Technologies support personnel.

Setting Description	Default Value
PWM Frequency	10 Hz
On Pulse duration	38
Hold current frequency	10 counts
Hold current duty cycle	5 counts
Phase offset	128 counts
Jump Point	5 psi or 0.35 bar.
Max Duty Cycle	80% (all ON above this value)
PWM Off Time	0 counts

Enable/Disable Options

To enter the OEM Setup:

1. Press the TeeJet logo 3 times within the first three seconds of the Splash screen being displayed. The console will beep to acknowledge the OEM option has been activated.

Figure 17: OEM Setup



TUNING DYNAJET®

1. Identify the speed range, rate range and system pressures for the application. Ensure the operating conditions are compatible with the tip capacity, speeds and duty cycles shown in the TeeJet PWM tip selection guide.
2. Using the identified speed range based on tip selection use the rate controllers test speed or simulated speed to target a desired application rate and droplet size.
3. Fine tune the regulation performance of the rate control system and the DynaJet system.
 - a. Typical settings used for DynaJet fine-tuning include Fine Gain, Coarse Gain, Coarse Gain On and Coarse Gain Off.
 - b. Coarse Gain On must be a higher value than coarse gain Off. A good starting point for Coarse Gain On is a pressure value that is about 35-40% of the target pressure.
 - c. Coarse Gain Off value is typically is about 25% of the target pressure, or 5-10 PSI (0.3 - 0.6 bar) lower than Coarse Gain On.
 - d. Coarse Gain On and Coarse Gain % are used to make major adjustments to pressure regulation. Once coarse gain has brought pressure near target; Coarse Gain Off and Fine Gain will influence the smaller adjustments.
 - e. Coarse Gain should be increased if large pressure adjustments need to be made more quickly.
 - f. Fine Gain should be decreased if actual pressure constantly moves across the target pressure.

DynaJet and the existing rate controller are two control systems that must coexist. Because DynaJet is a second control device that is installed on the same liquid system, users should be prepared to adjust the rate controller regulation settings to harmonize the two system. For example, if subtle changes in duty cycle on DynaJet induce noticeable rate or pressure oscillations, the rate control regulation gain settings may need to be reduced. Placing the rate control system in manual regulation mode during the tuning process will help determine if oscillations are being caused by the DynaJet or by the rate controller.

TeeJet control systems like 844E, 854 or Radion will typically perform better with DynaJet when their Coarse and Fine regulating speeds are reduced by 2-3 units.

General rule of thumb under normal operating conditions for flow rate changes; DynaJet in combination with the rate controller should have rate/pressure stabilized in ~ 2-3 seconds.

DYNAJET® TIP SELECTION

Selection of the proper spray tip for use with the DynaJet system is much like selecting the spray tip for a traditional spraying operation. Along with the extra application flexibility, DynaJet brings a few other tip-related considerations that will be summarized below.

1. Duty Cycle

- a. DynaJet Flex controls tip flow rate by varying the portion of time that each tip is 'on' vs. 'off'. The on time is referred to as Duty Cycle. The range of duty cycle available is typically 30% to 100%, meaning that the tips on the machine will have the approximately 30% to 100% of their rated flow capacity.
- b. With the DynaJet System:
 - Standard Mode $\text{Spray Tip Flow Capacity} = \text{Spray Tip Size} \times \text{Duty Cycle}$
 - High Flow Mode $\text{Spray Tip Flow Capacity} = \text{Spray Tip Size} \times \text{Duty Cycle} \times 2$
- c. By varying the duty cycle, the DynaJet Flex is essentially varying spray tip capacity on the fly. When more pressure is required, the tip capacity (duty cycle) is reduced. When higher tip capacity is required, the duty cycle is increased.
- d. Although the operator has a much more flexible and forgiving application system with DynaJet, care should be taken to select spray tips that give the best possible results.
- e. When selecting a spray tip, review the DynaJet tip selection charts and select a spray tip capacity that produces the target application rate at a duty cycle of about 70% when running at expected travel speeds. In other words, choose tip capacity and desired pressure/droplet size closer to the high end of the speed (or rate) range than to the lower end. This will provide plenty of adjustment range for DynaJet to reduce duty cycle when travel speed slows, while also providing additional capacity if travel speed increases above the planned speed.
 - The default setting for minimum duty cycle is 30%. This means the system will not adjust the duty cycle below 30% 'on'. While this setting can be set as low as 20% by the operator, the higher default value provides a more uniform application at lower speeds.

2. Spray Tip Selection

- a. The DynaJet system is not compatible with air inducted spray tips. Be sure to select a conventional spray tip for use with the system. The recommended options are XR TeeJet, DG TeeJet, Turbo TwinJet and Turbo TeeJet.
- b. Different tip styles have different droplet size characteristics across the range of operating pressures. The spray tip style should be selected based on the desired droplet size at the pressures expected to be in use for your application.
- c. Always use spray tips with 110° (or wider) spray pattern. These spray tip part numbers will typically include the 110 in their name – for example TT11006VP or XR11006-VS. 80° spray tips are not recommended with DynaJet.

3. Spray Height

- a. In order to achieve the best possible spray coverage, make sure to keep spray height at or above 20" from the tip to the target.

Tip Selection Example

These columns show flow rates at various pressures. The Delta P represents pressure loss through the DynaJet solenoid valve, and the resulting Tip PSI and Flow show actual values at the spray tip.

These columns show droplet sizes for different styles of spray tip at given pressures. Use these columns to choose the best tip style for your application.

Just like a normal tip chart, these columns show rates available at given speeds. The only difference is the range of values that corresponds to the range of flows available with DynaJet Flex.

Tip No.	Gauge Pressure PSI	Rated GPM	Δ P	Tip		Min Duty Cycle 30%		Tip Spacing 20 inches			
								TT	TTJ60	6 mph	8 mph
				PSI	Flow	GPA	GPA			GPA	GPA
11006 TT TJ60 TTJ60 XR XRC (50)	20	0.42	3	17	0.39	XC	-	5.8 to 19.3	4.3 to 14.5	3.5 to 11.6	2.9 to 9.7
	30	0.52	4	26	0.48	VC	VC	7.1 to 24	5.3 to 17.8	4.3 to 14.3	3.6 to 11.9
	40	0.60	5	35	0.56	VC	C	8.3 to 28	6.2 to 21	5.0 to 16.6	4.2 to 13.9
	50	0.67	6	44	0.63	VC	C	9.4 to 31	7.0 to 23	5.6 to 18.7	4.7 to 15.6
	60	0.73	7	53	0.69	C	C	10.2 to 34	7.7 to 26	6.1 to 20	5.1 to 17.1
	70	0.79	8	62	0.74	C	C	11.0 to 37	8.2 to 27	6.6 to 22	5.5 to 18.3
	80	0.85	9	71	0.80	C	C	11.9 to 40	8.9 to 30	7.1 to 24	5.9 to 19.8
	90	0.90	10	80	0.85	M	C	12.6 to 42	9.5 to 32	7.6 to 25	6.3 to 21

If the operator wants to apply 15 GPA at 10 MPH, he would look in the 10 MPH column, and find the row that shows 15 GPA with room above and below to compensate for higher and lower speeds that may be experienced in the field. In this case a TT11006 at 40-50 PSI will work very well.

Tip No.	Gauge Pressure PSI	Rated GPM	Δ P	Tip		Min Duty Cycle 30%		Tip Spacing 20 inches			
								TT	TTJ60	6 mph	8 mph
				PSI	Flow	GPA	GPA			GPA	GPA
11006 TT TJ60 TTJ60 XR XRC (50)	20	0.42	3	17	0.39	XC	-	5.8 to 19.3	4.3 to 14.5	3.5 to 11.6	2.9 to 9.7
	30	0.52	4	26	0.48	VC	VC	7.1 to 24	5.3 to 17.8	4.3 to 14.3	3.6 to 11.9
	40	0.60	5	35	0.56	VC	C	8.3 to 28	6.2 to 21	5.0 to 16.6	4.2 to 13.9
	50	0.67	6	44	0.63	VC	C	9.4 to 31	7.0 to 23	5.6 to 18.7	4.7 to 15.6
	60	0.73	7	53	0.69	C	C	10.2 to 34	7.7 to 26	6.1 to 20	5.1 to 17.1
	70	0.79	8	62	0.74	C	C	11.0 to 37	8.2 to 27	6.6 to 22	5.5 to 18.3
	80	0.85	9	71	0.80	C	C	11.9 to 40	8.9 to 30	7.1 to 24	5.9 to 19.8
	90	0.90	10	80	0.85	M	C	12.6 to 42	9.5 to 32	7.6 to 25	6.3 to 21

The next consideration is droplet size. The chart shows that a Turbo TeeJet (TT) tip will give Very Coarse (VC) droplets in this pressure range, and a Turbo TwinJet (TTJ60) will give Coarse (C) droplets. The benefit of the TT is that the operator could select droplets from VC to M all at the same rate and speed.

Tip No.	Gauge Pressure PSI	Rated GPM	Δ P	Tip		Min Duty Cycle 30%		Tip Spacing 20 inches			
								TT	TTJ60	6 mph	8 mph
				PSI	Flow	GPA	GPA			GPA	GPA
11006 TT TJ60 TTJ60 XR XRC (50)	20	0.42	3	17	0.39	XC	-	5.8 to 19.3	4.3 to 14.5	3.5 to 11.6	2.9 to 9.7
	30	0.52	4	26	0.48	VC	VC	7.1 to 24	5.3 to 17.8	4.3 to 14.3	3.6 to 11.9
	40	0.60	5	35	0.56	VC	C	8.3 to 28	6.2 to 21	5.0 to 16.6	4.2 to 13.9
	50	0.67	6	44	0.63	VC	C	9.4 to 31	7.0 to 23	5.6 to 18.7	4.7 to 15.6
	60	0.73	7	53	0.69	C	C	10.2 to 34	7.7 to 26	6.1 to 20	5.1 to 17.1
	70	0.79	8	62	0.74	C	C	11.0 to 37	8.2 to 27	6.6 to 22	5.5 to 18.3
	80	0.85	9	71	0.80	C	C	11.9 to 40	8.9 to 30	7.1 to 24	5.9 to 19.8
	90	0.90	10	80	0.85	M	C	12.6 to 42	9.5 to 32	7.6 to 25	6.3 to 21

55295 E-CHEMSAVER® MAINTENANCE INSTRUCTIONS

The 55295 e-ChemSaver is a solenoid-actuated shutoff compatible with a wide range of TeeJet tip bodies equipped with a diaphragm check valve. It can be used for end-of-boom tips as well as individual tip shutoff and PWM controls.

The valve is normally closed and opens when the solenoid is energized. The 55295 has a 2-Pin MetriPack connector molded into the body for a clean, weather-tight electrical connection.

General Disassembly and Reassembly

NOTE: O-rings (8, 9, 10) should be handled with care as they can be damaged/deformed

- Loosen and remove the Nylon Nut (4) and Stainless Steel Washer (5)
- Separate the Coil Assembly (1) from the rest of the Tube/Plunger Assembly (2, 3, 6-11)
- Remove the Locking Ring (11)
- Using pliers to grip the Stainless Steel Interface Cap (7), loosen the Tube Sub-Assembly (2) using a 9/16" (14 mm) or adjustable wrench. Note a low-profile 9/16" wrench is available from TeeJet using part number 97-00067.

All repairable parts should be accessible at this point. The Plunger Sub-Assembly (3), Stainless Steel Spring (6), and O-rings (8, 9, 10) can be replaced without further disassembly

- During reassembly, place the Plunger Sub-Assembly (3) and Stainless Steel Spring (6) in the Tube Sub-Assembly (2)

NOTE: The Plunger Sub-Assembly (3) should be oriented with the black insert facing outward (visible) when placed in the Tube Sub-Assembly (2)

- While compressing the Spring (6), thread the Tube/Plunger Assembly (2, 3, 6-11) to the Stainless Steel Interface Cap (7) and tighten using a wrench and pliers

Optional: Apply 1 drop of Loctite Blue 243 to the threads of the Interface Cap (7) and Tube Sub-Assembly (2)

Torque Specifications: tighten Interface Cap (7) and Tube Sub-Assembly (2) to 12 in-lbs (1.36 N-m)

- Return the Locking Ring (11) to its original position and slide the Tube/Plunger Assembly (2, 3, 6-11) through the Coil Assembly (1)

NOTE: The Coil Assembly (1) should be oriented with the MetriPack connectors facing away from the Interface Cap (7)

- Place the Stainless Steel Washer (5) above the Coil Assembly (1) and tighten the Nylon Nut (4) to the Tube/Plunger Assembly (2, 3, 6-11)

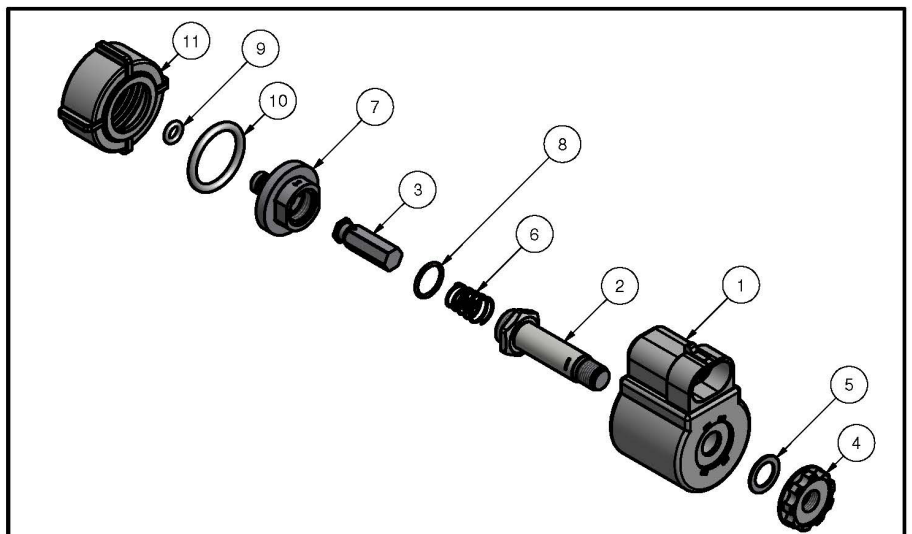

ITEM	PART NUMBER	DESCRIPTION
1	CP55296-12	12 VOLT COIL ASSEMBLY (55295-1-12, 55295-2-12, & 55295-4-12)
1A	CP55296-24	24 VOLT COIL ASSEMBLY (55295-1-24, 55295-2-24, & 55295-4-24)
2	N/A	TUBE SUB ASSEMBLY
3	N/A	PLUNGER SUB-ASSEMBLY
4	N/A	NUT, NYLON-BLACK
5	N/A	WASHER, 303 STAINLESS STEEL
6	N/A	SPRING, 302 STAINLESS STEEL
7	N/A	INTERFACE CAP, 303 STAINLESS STEEL (55295-1-12 & 55295-4-12)
7A	N/A	INTERFACE CAP, 303 STAINLESS STEEL (55295-2-12)
8	N/A	O-RING, VITON
9	N/A	O-RING, VITON (55295-1-12 & 55295-4-12)
9A	N/A	O-RING, VITON (55295-2-12)
10	N/A	O-RING, VITON (55295-1-12 & 55295-2-12)
10A	N/A	GASKET, VITON (55295-4-12)
11	N/A	LOCKING RING, NYLON-BLACK
AB55295-1-KIT, SPARE PARTS KIT (INCLUDES 3, 6, 8, 9, 10)		
AB55295-2-KIT, SPARE PARTS KIT (INCLUDES 3, 6, 8, 9A, 10)		
AB55295-4-KIT, SPARE PARTS KIT (INCLUDES 3, 6, 8, 9, 10A)		

DESCRIPTION:

55295-1-12, 55295-2-12, 55295-4-12,
55295-1-24, 55295-2-24, 55295-4-24
e-CHEMSAVER® SOLENOID OPERATED
ELECTRIC SHUT-OFF VALVE



Spraying Systems Co.®
Spray Nozzles and Accessories
P.O. Box 7900 - Wheaton, IL 60189-7900

REVISION NO.

REFERENCE:

PARTS LIST
PL55295

SHEET:

DWG SIZE:

A

Figure 19: Metric - Standard Mode

Tip No.	Gauge Pressure (Bar)	Rated L/Min	Δ P	Tip		Minimum Duty Cycle				30%		Tip Spacing 50 cm								
				Pressure (Bar)	Flow (L/Min)	XR/XRC	TT	TJ60	TTJ60	DG	5 km/h I/ha	6 km/h I/ha	8 km/h I/ha	10 km/h I/ha	12 km/h I/ha	14 km/h I/ha	16 km/h I/ha	18 km/h I/ha	20 km/h I/ha	
11004 DG TT TJ60 TTJ60 XR XRC (60)	1.5	1.12	0.2	1.3	1.03	M	VC	-	VC	-	-	117 to 247	98 to 206	73 to 185	59 to 124	49 to 103	42 to 88	37 to 77	33 to 69	29 to 62
	2	1.29	0.3	1.7	1.21	M	VC	F	VC	VC	C	132 to 290	110 to 242	83 to 182	66 to 145	55 to 121	47 to 104	41 to 91	37 to 81	33 to 73
	3	1.58	0.3	2.7	1.50	M	C	F	C	C	C	158 to 360	132 to 300	99 to 225	79 to 180	66 to 150	57 to 129	49 to 113	44 to 100	40 to 90
	4	1.82	0.3	3.7	1.75	F	M	F	M	M	M	179 to 420	149 to 350	112 to 263	90 to 210	75 to 175	64 to 150	56 to 131	50 to 117	45 to 105
	5	2.04	0.3	4.7	1.97	-	M	-	-	-	-	195 to 473	162 to 394	122 to 296	98 to 236	81 to 197	70 to 168	61 to 148	54 to 131	49 to 118
	6	2.23	0.4	5.6	2.16	-	M	-	-	-	-	207 to 518	172 to 432	129 to 324	103 to 259	86 to 216	74 to 185	65 to 162	57 to 144	52 to 130
	7	2.41	0.4	6.6	2.34	-	-	-	-	-	-	214 to 562	178 to 468	134 to 351	107 to 281	89 to 234	76 to 201	67 to 176	59 to 156	53 to 140
11005 DG TT TJ60 TTJ60 XR XRC (60)	1.5	1.39	0.3	1.2	1.26	M	XC	-	VC	-	-	141 to 302	118 to 252	88 to 189	71 to 151	59 to 126	44 to 95	39 to 84	35 to 76	
	2	1.61	0.3	1.7	1.49	M	VC	M	VC	VC	C	161 to 358	134 to 298	101 to 224	81 to 179	67 to 149	50 to 112	45 to 99	40 to 89	
	3	1.97	0.3	2.7	1.86	M	C	M	C	C	C	193 to 446	161 to 372	121 to 279	97 to 223	81 to 186	69 to 159	60 to 140	54 to 124	
	4	2.27	0.4	3.6	2.16	F	C	F	M	M	M	217 to 518	181 to 432	136 to 324	109 to 259	91 to 216	78 to 185	68 to 162	60 to 144	
	5	2.54	0.4	4.6	2.44	-	M	-	M	M	M	235 to 586	196 to 488	147 to 366	118 to 293	98 to 244	84 to 209	74 to 183	65 to 163	
	6	2.79	0.5	5.5	2.68	-	M	-	M	M	M	250 to 643	208 to 536	156 to 402	125 to 322	104 to 268	89 to 230	78 to 201	69 to 179	
	7	3.01	0.5	6.5	2.90	-	-	-	-	-	-	264 to 696	220 to 580	165 to 435	132 to 348	110 to 290	94 to 249	82 to 218	73 to 193	
11006 TT TJ60 TTJ60 XR XRC (60)	1.5	1.68	0.3	1.2	1.51	C	XC	-	VC	-	-	169 to 362	141 to 302	105 to 227	84 to 181	70 to 151	60 to 129	53 to 113	47 to 101	
	2	1.94	0.3	1.7	1.78	M	VC	M	VC	VC	C	192 to 427	160 to 356	120 to 267	96 to 214	80 to 178	69 to 153	60 to 134	53 to 119	
	3	2.37	0.4	2.6	2.22	M	VC	M	C	C	C	232 to 533	193 to 444	145 to 333	116 to 266	97 to 222	83 to 190	73 to 167	64 to 148	
	4	2.74	0.4	3.6	2.58	M	C	F	C	C	C	263 to 619	219 to 516	165 to 387	132 to 310	110 to 258	94 to 221	82 to 194	73 to 172	
	5	3.06	0.5	4.5	2.90	-	M	-	M	M	M	287 to 696	239 to 580	179 to 435	144 to 348	120 to 290	103 to 249	90 to 218	80 to 193	
	6	3.35	0.6	5.4	3.18	-	M	-	M	M	M	304 to 763	253 to 636	190 to 477	152 to 382	127 to 318	109 to 273	95 to 239	84 to 212	
	7	3.62	0.7	6.3	3.44	-	-	-	-	-	-	315 to 826	262 to 688	197 to 516	157 to 413	131 to 344	112 to 295	98 to 258	87 to 229	
11008 TT TJ60 TTJ60 XR XRC (60)	1.5	2.23	0.4	1.1	1.95	C	XC	-	VC	-	-	205 to 468	171 to 390	128 to 293	102 to 234	85 to 195	73 to 167	64 to 146	57 to 130	
	2	2.58	0.4	1.6	2.30	C	VC	M	VC	VC	C	231 to 552	192 to 460	144 to 345	115 to 276	96 to 230	82 to 197	72 to 173	64 to 153	
	3	3.16	0.5	2.5	2.86	M	VC	M	C	C	C	276 to 686	230 to 572	172 to 429	138 to 343	115 to 286	99 to 245	86 to 215	77 to 191	
	4	3.65	0.7	3.3	3.32	M	C	M	C	C	C	311 to 797	259 to 664	194 to 498	155 to 398	130 to 332	111 to 285	97 to 249	86 to 221	
	5	4.08	0.9	4.1	3.72	M	C	M	C	C	C	335 to 893	279 to 744	210 to 568	168 to 446	140 to 372	120 to 319	105 to 279	93 to 248	
	6	4.47	1.0	5.0	4.07	-	M	-	C	C	C	348 to 977	290 to 814	218 to 611	174 to 488	145 to 407	124 to 349	109 to 305	97 to 271	
	7	4.83	1.2	5.8	4.39	-	-	-	M	M	M	350 to 1054	291 to 878	219 to 659	175 to 527	146 to 439	125 to 376	109 to 329	97 to 293	
11010 TJ60 TTJ60 XR XRC (60)	1.5	2.79	0.5	1.0	2.33	VC	-	-	-	-	-	241 to 559	201 to 466	151 to 350	121 to 280	101 to 230	86 to 200	75 to 175	67 to 155	
	2	3.23	0.6	1.4	2.74	C	-	-	XC	-	-	276 to 658	230 to 548	173 to 411	138 to 329	115 to 274	99 to 235	86 to 206	77 to 183	
	3	3.95	0.8	2.2	3.38	C	-	M	VC	VC	C	332 to 811	277 to 676	208 to 507	166 to 406	138 to 338	119 to 290	104 to 254	92 to 225	
	4	4.56	1.1	2.9	3.90	M	-	M	VC	VC	C	371 to 936	309 to 780	232 to 585	185 to 468	155 to 390	132 to 334	116 to 293	103 to 260	
	5	5.10	1.4	3.6	4.34	M	-	M	VC	VC	C	394 to 1042	329 to 868	246 to 651	197 to 521	164 to 434	141 to 372	123 to 326	110 to 289	
	6	5.59	1.7	4.3	4.75	M	-	-	C	C	C	404 to 1140	337 to 950	252 to 713	202 to 571	168 to 475	144 to 407	126 to 356	112 to 317	

Figure 20: US - High Flow Mode

Tip No.	Gauge Pressure PSI	Rated GPM	Δ P	Tip		Minimum Duty Cycle						Tip Spacing 20 inches											
				PSI	Flow	XR/XRC	TT	T160	TT160	DG	5.0 GPA	7.5 GPA	10.0 GPA	12.0 GPA	15.0 GPA	17.5 GPA	20.0 GPA	25.0 GPA	30.0 GPA				
11004 DG TT T160 TT160 XR XRC (50)	20	0.28	3	17	0.26	M	XC	-	-	-	7.4 to 15.4	4.9 to 10.3	3.7 to 7.7	3.1 to 6.4	2.5 to 5.1	2.1 to 4.4	1.8 to 3.9	1.5 to 3.1	1.2 to 2.6				
	30	0.35	4	26	0.33	M	VC	F	C	-	8.9 to 19.6	5.9 to 13.1	4.4 to 9.8	3.7 to 8.2	3.0 to 6.5	2.5 to 5.6	2.2 to 4.9	1.8 to 3.9	1.5 to 3.3				
	40	0.40	4	36	0.38	M	M	F	C	-	10.0 to 23	6.7 to 15.0	5.0 to 11.3	4.2 to 9.4	3.3 to 7.5	2.9 to 6.4	2.5 to 5.6	2.0 to 4.5	1.7 to 3.8				
	50	0.45	4	46	0.43	F	M	F	M	M	11.0 to 26	7.3 to 17.0	5.5 to 12.8	4.6 to 10.6	3.7 to 8.5	3.1 to 7.3	2.7 to 6.4	2.2 to 5.1	1.8 to 4.3				
	60	0.49	5	55	0.47	F	M	F	M	M	12.9 to 30	6.9 to 18.6	6.0 to 14.0	5.3 to 12.6	4.0 to 9.3	3.4 to 8.0	3.0 to 7.6	2.4 to 5.6	2.0 to 4.7				
11005 DG TT T160 TT160 XR XRC (50)	70	0.53	5	65	0.51	-	M	-	M	-	12.7 to 30	8.4 to 20	6.3 to 15.1	5.3 to 12.6	4.2 to 10.1	3.6 to 8.7	3.2 to 7.6	2.5 to 6.1	2.1 to 5.0				
	80	0.57	5	75	0.55	-	M	-	M	-	13.3 to 33	8.9 to 22	6.7 to 16.3	5.6 to 13.6	4.4 to 10.9	3.8 to 9.3	3.3 to 8.2	2.7 to 6.5	2.2 to 5.4				
	90	0.60	5	85	0.58	-	M	-	M	-	13.7 to 34	9.1 to 23	6.9 to 17.2	5.6 to 14.4	3.9 to 17.2	3.4 to 9.8	3.2 to 8.6	2.7 to 6.9	2.3 to 5.7				
	20	0.35	4	16	0.32	M	XC	-	-	-	8.9 to 19.0	5.9 to 12.7	4.5 to 9.5	3.7 to 7.9	3.0 to 6.3	2.5 to 5.4	2.2 to 4.8	1.8 to 3.8	1.5 to 3.2				
	30	0.43	4	26	0.40	M	VC	-	C	-	10.7 to 24	7.1 to 15.8	5.3 to 11.9	4.4 to 9.9	3.6 to 7.9	3.0 to 6.8	2.7 to 5.9	2.1 to 4.8	1.8 to 4.0				
11006 TT T160 TT160 XR XRC (50)	40	0.50	5	35	0.47	M	VC	M	C	-	12.2 to 28	8.1 to 18.6	6.1 to 14.0	5.1 to 11.6	4.1 to 9.3	3.5 to 8.0	3.0 to 7.0	2.4 to 5.6	2.0 to 4.7				
	50	0.56	5	45	0.53	M	M	M	C	-	13.4 to 31	8.9 to 21	6.7 to 15.7	5.6 to 13.1	4.5 to 10.5	3.8 to 9.0	3.4 to 7.9	2.7 to 6.3	2.2 to 5.2				
	60	0.61	5	55	0.58	F	C	F	M	M	14.6 to 34	9.7 to 23	7.3 to 17.2	6.1 to 14.4	4.9 to 11.5	4.2 to 9.8	3.6 to 8.6	2.9 to 6.9	2.4 to 5.7				
	70	0.66	6	64	0.63	F	M	F	M	M	15.3 to 37	10.2 to 25	7.6 to 18.7	6.4 to 15.6	5.1 to 12.5	4.4 to 10.7	3.8 to 9.4	3.1 to 7.5	2.5 to 6.2				
	80	0.71	6	74	0.68	-	M	-	M	-	15.8 to 40	10.6 to 27	7.9 to 20	6.6 to 16.8	5.3 to 13.5	4.5 to 11.5	4.0 to 10.1	3.2 to 8.1	2.6 to 6.7				
11008 TT T160 TT160 XR XRC (50)	90	0.75	7	83	0.72	-	M	-	M	-	16.8 to 43	11.2 to 29	8.4 to 21	7.0 to 17.8	5.8 to 14.3	4.8 to 12.2	4.2 to 10.7	3.4 to 8.6	2.8 to 7.1				
	20	0.42	4	16	0.37	C	XC	-	-	-	10.7 to 22	7.1 to 14.7	5.3 to 11.0	4.4 to 9.2	3.6 to 7.3	3.0 to 6.3	2.7 to 5.5	2.1 to 4.4	1.8 to 3.7				
	30	0.52	5	25	0.48	M	VC	-	C	-	12.7 to 29	8.5 to 19.0	6.4 to 14.3	5.3 to 11.9	4.2 to 9.5	3.6 to 8.1	3.2 to 7.1	2.5 to 5.7	2.1 to 4.8				
	40	0.60	5	35	0.56	M	M	M	C	-	14.5 to 33	9.7 to 22	7.3 to 16.6	6.1 to 13.9	4.8 to 11.1	4.2 to 9.5	3.6 to 8.3	2.9 to 6.7	2.4 to 5.5				
	50	0.67	6	44	0.63	M	VC	M	C	-	16.3 to 37	10.9 to 25	8.1 to 18.7	6.8 to 15.6	5.4 to 12.5	4.7 to 10.7	4.1 to 9.4	3.3 to 7.5	2.7 to 6.2				
11010 TT160 TT160 XR XRC (50)	60	0.73	6	54	0.69	M	C	F	M	-	17.3 to 41	11.6 to 27	8.7 to 20	7.2 to 17.1	5.8 to 13.7	5.0 to 11.7	4.3 to 10.2	3.5 to 8.2	2.9 to 6.8				
	70	0.79	7	63	0.75	F	C	F	M	M	18.5 to 45	12.3 to 30	9.2 to 22	7.7 to 18.6	6.2 to 14.9	5.3 to 12.7	4.6 to 11.1	3.7 to 8.9	3.1 to 7.4				
	80	0.85	8	72	0.81	C	M	-	M	-	19.3 to 48	12.8 to 32	9.6 to 24	8.0 to 20	6.4 to 16.0	5.5 to 13.7	4.8 to 12.0	3.9 to 9.6	3.2 to 8.5				
	90	0.90	9	81	0.86	-	M	-	M	-	19.9 to 51	13.3 to 34	9.9 to 26	8.3 to 21	6.6 to 17.0	5.7 to 14.6	5.0 to 12.8	4.0 to 10.2	3.3 to 8.5				
	20	0.57	5	15	0.49	C	XC	-	-	-	12.8 to 29	8.6 to 19.4	6.4 to 14.6	5.4 to 12.1	4.3 to 9.7	3.7 to 8.3	3.2 to 7.3	2.6 to 5.8	2.1 to 4.9				
TT160 TT160 XR XRC (50)	30	0.69	6	24	0.62	C	VC	-	VC	-	15.4 to 37	10.3 to 25	7.7 to 18.4	6.4 to 15.3	5.1 to 12.3	4.4 to 10.5	3.9 to 9.2	3.1 to 7.4	2.6 to 6.1				
	40	0.80	7	33	0.72	M	VC	M	VC	-	17.8 to 43	11.9 to 29	8.9 to 21	7.4 to 17.8	5.9 to 14.3	5.1 to 12.2	4.4 to 10.7	3.6 to 8.6	3.0 to 7.1				
	50	0.89	9	41	0.81	M	C	M	C	-	18.5 to 48	12.3 to 32	9.2 to 24	7.7 to 20	6.2 to 16.0	5.3 to 13.7	4.6 to 12.0	3.7 to 9.6	3.1 to 8.0				
	60	0.98	10	50	0.89	M	M	M	C	-	21 to 53	13.8 to 35	10.4 to 26	8.6 to 22	6.9 to 17.6	5.9 to 15.1	5.2 to 13.2	4.1 to 10.6	3.5 to 8.8				
	70	1.06	12	58	0.97	M	C	M	C	-	22 to 58	14.5 to 38	10.9 to 29	9.0 to 24	7.2 to 19.2	6.2 to 16.5	5.4 to 14.4	4.3 to 11.5	3.6 to 9.6				
TT160 TT160 XR XRC (50)	80	1.13	13	67	1.03	-	C	-	C	-	22 to 61	15.0 to 41	11.2 to 31	9.4 to 25	7.5 to 20	6.4 to 17.5	5.6 to 15.3	4.5 to 12.2	3.7 to 10.2				
	90	1.20	15	75	1.09	-	C	-	M	-	23 to 65	15.1 to 43	11.3 to 32	9.4 to 27	7.5 to 22	6.5 to 18.5	5.7 to 16.2	4.5 to 12.9	3.8 to 10.8				
	30	0.87	8	22	0.74	C	-	-	VC	-	18.2 to 44	12.1 to 29	9.1 to 22	7.6 to 18.3	6.1 to 14.7	5.2 to 12.6	4.6 to 11.0	3.6 to 8.8	3.0 to 7.3				
	40	1.00	11	29	0.86	C	-	-	VC	-	21 to 51	13.9 to 34	10.4 to 26	8.7 to 21	6.9 to 17.0	6.0 to 14.6	5.2 to 12.8	4.2 to 10.2	3.5 to 8.5				
	50	1.12	13	37	0.96	C	-	-	VC	-	23 to 57	15.4 to 38	11.6 to 29	9.6 to 24	7.7 to 19.0	6.6 to 16.3	5.8 to 14.3	4.6 to 11.4	3.9 to 9.5				
TT160 TT160 XR XRC (50)	60	1.22	16	44	1.05	M	VC	-	VC	-	25 to 62	16.5 to 42	12.3 to 31	10.3 to 26	8.2 to 21	7.1 to 17.8	6.3 to 15.6	4.9 to 12.5	4.1 to 10.4				
	70	1.32	19	51	1.13	M	VC	-	VC	-	25 to 67	16.9 to 45	12.7 to 34	10.5 to 28	8.5 to 22	7.3 to 19.2	6.3 to 16.8	5.1 to 13.4	4.2 to 11.2				
	80	1.41	22	58	1.20	M	-	-	C	-	26 to 71	17.4 to 48	13.0 to 36	10.9 to 30	8.7 to 24	7.4 to 20	6.5 to 17.8	5.2 to 14.3	4.3 to 11.9				

Figure 21: Metric - High Flow Mode

Tip No.	Gauge Pressure (Bar)	Rated L/Min	Δ P	Tip		Minimum Duty Cycle				30%		Tip Spacing 50 cm									
				Pressure (Bar)	Flow (L/Min)	XR/XRC	TT	T.J60	TTJ60	DG	50 l/ha	75 l/ha	100 l/ha	125 l/ha	150 l/ha	200 l/ha	225 l/ha	250 l/ha	300 l/ha		
																				VC	VC
11004 DG TT TJ60 TTJ60 XR XRC (50)	1.5	1.12	0.2	1.3	1.03	M	VC	-	VC	-	-	12 to 25	7.8 to 16	5.9 to 12	4.7 to 9.9	3.9 to 8.2	2.9 to 6.2	2.6 to 5.5	2.3 to 4.9	2.0 to 4.1	
	2	1.29	0.3	1.7	1.21	M	VC	F	VC	C	C	13 to 29	8.8 to 19	6.6 to 15	5.3 to 12	4.4 to 9.7	3.3 to 7.3	2.9 to 6.5	2.6 to 5.8	2.2 to 4.8	
	3	1.58	0.3	2.7	1.50	M	C	F	C	C	C	16 to 36	11 to 24	7.9 to 18	6.3 to 14	5.3 to 12	4.0 to 9.0	3.5 to 8.0	3.2 to 7.2	2.6 to 6.0	
	4	1.82	0.3	3.7	1.75	F	M	F	M	M	M	18 to 42	12 to 28	9.0 to 21	7.2 to 17	6.0 to 14	4.5 to 11	4.0 to 9.3	3.6 to 8.4	3.0 to 7.0	
	5	2.04	0.3	4.7	1.97	-	M	-	M	-	-	20 to 47	13 to 32	9.8 to 24	8.5 to 19	6.5 to 16	4.9 to 12	4.3 to 11	3.9 to 9.5	3.3 to 7.9	
	6	2.23	0.4	5.6	2.16	-	M	-	M	-	-	21 to 52	14 to 35	10 to 26	8.3 to 21	6.9 to 17	5.2 to 13	4.6 to 12	4.1 to 10	3.4 to 8.6	
	7	2.41	0.4	6.6	2.34	-	M	-	M	-	-	21 to 56	14 to 37	11 to 28	8.6 to 22	7.1 to 19	5.3 to 14	4.8 to 12	4.3 to 11	3.6 to 9.4	
11005 DG TT TJ60 TTJ60 XR XRC (50)	1.5	1.39	0.3	1.2	1.26	M	VC	-	VC	-	-	14 to 30	9.4 to 20	7.1 to 15	5.6 to 12	4.7 to 10	3.5 to 7.6	3.1 to 6.7	2.8 to 6.0	2.4 to 5.0	
	2	1.61	0.3	1.7	1.49	M	VC	M	VC	C	C	16 to 36	11 to 24	8.1 to 18	6.4 to 14	5.4 to 12	4.0 to 8.9	3.6 to 7.9	3.2 to 7.2	2.7 to 6.0	
	3	1.97	0.3	2.7	1.86	M	C	M	C	C	C	19 to 45	13 to 30	9.7 to 22	7.7 to 18	6.4 to 15	4.8 to 11	4.3 to 9.9	3.9 to 8.9	3.2 to 7.4	
	4	2.27	0.4	3.6	2.16	F	C	F	C	M	M	22 to 52	14 to 35	11 to 26	8.7 to 21	7.2 to 17	5.4 to 13	4.8 to 12	4.3 to 10	3.6 to 8.6	
	5	2.54	0.4	4.6	2.44	-	M	-	M	-	-	24 to 59	16 to 39	12 to 29	9.4 to 23	7.8 to 20	5.9 to 15	5.2 to 13	4.7 to 12	3.9 to 9.8	
	6	2.79	0.5	5.5	2.68	-	M	-	M	-	-	25 to 64	17 to 43	12 to 32	10.0 to 26	8.3 to 21	6.2 to 16	5.6 to 14	5.0 to 13	4.2 to 11	
	7	3.01	0.5	6.5	2.90	-	M	-	M	-	-	26 to 70	18 to 46	13 to 35	11 to 28	8.8 to 23	6.6 to 17	5.9 to 15	5.3 to 14	4.4 to 12	
11006 TT TJ60 TTJ60 XR XRC (50)	1.5	1.51	0.3	1.2	1.51	C	XC	-	XC	-	-	17 to 36	11 to 24	8.4 to 18	6.8 to 14	5.6 to 12	4.2 to 9.1	3.8 to 8.1	3.4 to 7.2	2.8 to 6.0	
	2	1.94	0.3	1.7	1.78	M	VC	M	VC	C	C	19 to 43	13 to 28	9.6 to 21	7.7 to 17	6.4 to 14	4.8 to 11	4.3 to 9.5	3.8 to 8.5	3.2 to 7.1	
	3	2.37	0.4	2.6	2.22	M	VC	M	C	C	C	23 to 53	15 to 36	12 to 27	9.3 to 21	7.7 to 18	5.8 to 13	5.2 to 12	4.6 to 11	3.9 to 8.9	
	4	2.74	0.4	3.6	2.58	M	C	F	C	C	C	26 to 62	18 to 41	13 to 31	11 to 25	8.8 to 21	6.6 to 15	5.9 to 14	5.3 to 12	4.4 to 10	
	5	3.06	0.5	4.5	2.90	-	C	-	M	-	-	29 to 70	19 to 46	14 to 35	11 to 28	9.6 to 23	7.2 to 17	6.4 to 15	5.7 to 14	4.8 to 12	
	6	3.35	0.6	5.4	3.18	-	M	-	M	-	-	30 to 76	20 to 51	15 to 38	12 to 31	10 to 25	7.6 to 19	6.8 to 17	6.1 to 15	5.1 to 13	
	7	3.62	0.7	6.3	3.44	-	M	-	M	-	-	31 to 83	21 to 55	16 to 41	13 to 33	10 to 28	7.9 to 21	7.0 to 18	6.3 to 17	5.2 to 14	
11008 TT TJ60 TTJ60 XR XRC (50)	1.5	2.23	0.4	1.1	1.95	C	XC	-	XC	-	-	20 to 47	14 to 31	10 to 23	8.2 to 19	6.8 to 16	5.1 to 12	4.5 to 10	4.1 to 9.4	3.4 to 7.8	
	2	2.58	0.4	1.6	2.30	C	VC	M	VC	C	C	23 to 55	15 to 37	12 to 28	9.2 to 22	7.7 to 18	5.8 to 14	5.1 to 12	4.6 to 11	3.8 to 9.2	
	3	3.16	0.5	2.5	2.86	M	VC	M	VC	C	C	28 to 69	18 to 46	14 to 34	11 to 27	9.2 to 23	6.9 to 17	6.1 to 15	5.5 to 14	4.6 to 11	
	4	3.65	0.7	3.3	3.32	M	C	M	C	C	C	31 to 80	21 to 53	16 to 40	12 to 32	10 to 27	7.8 to 20	6.9 to 18	6.2 to 16	5.2 to 13	
	5	4.08	0.9	4.1	3.72	M	C	M	C	C	C	34 to 89	22 to 60	17 to 45	13 to 36	11 to 30	8.4 to 22	7.5 to 20	6.7 to 18	5.6 to 15	
	6	4.47	1.0	5.0	4.07	-	M	-	C	-	-	35 to 98	23 to 65	17 to 49	14 to 39	12 to 33	8.7 to 24	7.7 to 22	7.0 to 20	5.8 to 16	
	7	4.83	1.2	5.8	4.39	-	M	-	M	-	-	35 to 105	23 to 70	17 to 53	14 to 42	12 to 35	8.7 to 26	7.8 to 23	7.0 to 21	5.8 to 18	
11010 TJ60 TTJ60 XR XRC (50)	1.5	2.79	0.5	1.0	2.33	VC	-	-	-	-	-	24 to 56	16 to 37	12 to 28	9.7 to 22	8.0 to 19	6.0 to 14	5.4 to 12	4.8 to 11	4.0 to 9.3	
	2	3.23	0.6	1.4	2.74	C	-	-	XC	-	-	28 to 66	18 to 44	14 to 33	11 to 26	9.2 to 22	6.9 to 16	6.1 to 15	5.5 to 13	4.6 to 11	
	3	3.95	0.8	2.2	3.38	C	-	M	VC	C	C	33 to 81	22 to 54	17 to 41	13 to 32	11 to 27	8.3 to 20	7.4 to 18	6.6 to 16	5.5 to 14	
	4	4.56	1.1	2.9	3.90	M	-	M	VC	C	C	37 to 94	25 to 62	19 to 47	15 to 37	12 to 31	9.3 to 23	8.2 to 21	7.4 to 19	6.2 to 16	
	5	5.10	1.4	3.6	4.34	M	-	M	VC	C	C	39 to 104	26 to 69	20 to 52	16 to 42	13 to 35	9.9 to 26	8.8 to 23	7.9 to 21	6.6 to 17	
	6	5.59	1.7	4.3	4.75	M	-	M	C	C	C	40 to 114	27 to 76	20 to 57	16 to 46	13 to 38	10 to 29	9.0 to 25	8.1 to 23	6.7 to 19	
	7	6.03	2.0	5.0	5.12	-	-	-	C	-	-	40 to 123	27 to 82	20 to 61	16 to 49	13 to 41	10 to 31	8.9 to 27	8.0 to 25	6.7 to 20	

Figure 22: US Turf - High Flow Mode

Tip No.	Gauge Pressure psi	Rated GPM	Δ P	Tip		Minimum Duty Cycle 30%		Tip Spacing 20 inches							
				PSI	Flow	XR/XRC	TT	1.0 Gal/1000ft ²	1.5 Gal/1000ft ²	2.0 Gal/1000ft ²	2.5 Gal/1000ft ²	3.0 Gal/1000ft ²	4.0 Gal/1000ft ²		
11006 TT XR XRC (50)	20	0.42	4	16	0.37	C	XC	1.2 to 5.0	0.8 to 3.4	0.6 to 2.5	0.5 to 2.0	0.4 to 1.7	0.3 to 1.3		
	30	0.52	5	25	0.48	M	VC	1.5 to 6.5	1.0 to 4.4	0.7 to 3.3	0.6 to 2.6	0.5 to 2.2	0.4 to 1.6		
	40	0.60	5	35	0.56	M	VC	1.7 to 7.6	1.1 to 5.1	0.8 to 3.8	0.7 to 3.0	0.6 to 2.5	0.4 to 1.9		
	50	0.67	6	44	0.63	M	VC	1.9 to 8.6	1.2 to 5.7	0.9 to 4.3	0.7 to 3.4	0.6 to 2.9	0.5 to 2.1		
	60	0.73	6	54	0.69	M	C	2.0 to 9.4	1.3 to 6.3	1.0 to 4.7	0.8 to 3.8	0.7 to 3.1	0.5 to 2.3		
	70	0.79	7	63	0.75	F	C	2.1 to 10.2	1.4 to 6.8	1.1 to 5.1	0.8 to 4.1	0.7 to 3.4	0.5 to 2.6		
	80	0.85	8	72	0.81	-	C	2.2 to 11.0	1.5 to 7.3	1.1 to 5.5	0.9 to 4.4	0.7 to 3.7	0.5 to 2.8		
	90	0.90	9	81	0.86	-	M	2.3 to 11.7	1.5 to 7.8	1.1 to 5.8	0.9 to 4.7	0.8 to 3.9	0.6 to 2.9		
	11008 TT XR XRC (50)	20	0.57	5	15	0.49	C	XC	1.5 to 6.7	1.0 to 4.4	0.7 to 3.3	0.6 to 2.7	0.5 to 2.2	0.4 to 1.7	
30		0.69	6	24	0.62	C	VC	1.8 to 8.4	1.2 to 5.6	0.9 to 4.2	0.7 to 3.4	0.6 to 2.8	0.4 to 2.1		
40		0.80	7	33	0.72	M	VC	2.0 to 9.8	1.4 to 6.5	1.0 to 4.9	0.8 to 3.9	0.7 to 3.3	0.5 to 2.4		
50		0.89	9	41	0.81	M	C	2.1 to 11.0	1.4 to 7.3	1.1 to 5.5	0.8 to 4.4	0.7 to 3.7	0.5 to 2.8		
60		0.98	10	50	0.89	M	C	2.4 to 12.1	1.6 to 8.1	1.2 to 6.1	0.9 to 4.8	0.8 to 4.0	0.6 to 3.0		
70		1.06	12	58	0.97	M	C	2.5 to 13.2	1.7 to 8.8	1.2 to 6.6	1.0 to 5.3	0.8 to 4.4	0.6 to 3.3		
80		1.13	13	67	1.03	-	C	2.6 to 14.0	1.7 to 9.3	1.3 to 7.0	1.0 to 5.6	0.9 to 4.7	0.6 to 3.5		
90		1.20	15	75	1.09	-	C	2.6 to 14.8	1.7 to 9.9	1.3 to 7.4	1.0 to 5.9	0.9 to 4.9	0.6 to 3.7		
11010 XR XRC (50)		30	0.87	8	22	0.74	C	-	2.1 to 10.1	1.4 to 6.7	1.0 to 5.0	0.8 to 4.0	0.7 to 3.4	0.5 to 2.5	
	40	1.00	11	29	0.86	C	-	2.4 to 11.7	1.6 to 7.8	1.2 to 5.8	1.0 to 4.7	0.8 to 3.9	0.6 to 2.9		
	50	1.12	13	37	0.96	C	-	2.6 to 13.1	1.8 to 8.7	1.3 to 6.5	1.1 to 5.2	0.9 to 4.4	0.7 to 3.3		
	60	1.22	16	44	1.05	M	-	2.8 to 14.3	1.9 to 9.5	1.4 to 7.1	1.1 to 5.7	0.9 to 4.8	0.7 to 3.6		
	70	1.32	19	51	1.13	M	-	2.9 to 15.4	1.9 to 10.2	1.5 to 7.7	1.2 to 6.1	1.0 to 5.1	0.7 to 3.8		
	80	1.41	22	58	1.20	M	-	3.0 to 16.3	2.0 to 10.9	1.5 to 8.2	1.2 to 6.5	1.0 to 5.4	0.7 to 4.1		

DYNAJET® FLEX

INSTALLATION, SETUP AND USER GUIDE

An innovative new product from TeeJet makes spraying more efficient and more productive. The DynaJet Flex system uses a touch screen controller and individual solenoids to control each spray tip. This innovative system works along with an existing rate controller, and allows the operator to choose specific droplet sizes that will be used for a particular job. The rate controller manages application rate, and the DynaJet system uses PWM technology to control system pressure and thereby control spray droplet size. Droplet size data is built into the controller so setup is easy and droplet sizes can be changed on the go. PWM control of each tip delivers very large ranges of speeds and application rates with a single spray tip and with consistent spray quality.



www.teejet.com

A Subsidiary of  *Spraying Systems Co.*

98-05334-ENUS-LT R2 English-US
© TeeJet Technologies 2016